

TECHNICAL MANUAL

OPERATOR'S AND ORGANIZATIONAL
MAINTENANCE MANUAL
INCLUDING REPAIR PARTS AND SPECIAL TOOL LISTS

SEARCHLIGHT SET,
INFRARED
AN/VSS-3A

NSN 5855-00-177-3529

NSN 5855-00-405-0404

<p>This copy is a reprint which includes current pages from Changes 1 through 10. The title was changed to read as shown above by C7.</p>

HEADQUARTERS, DEPARTMENT OF THE ARMY
2 JULY 1970

CHANGE }
No. 10 }

HEADQUARTERS
DEPARTMENT OF THE ARMY
WASHINGTON, DC ,31 March 1981

**Operator's and Organizational Maintenance Manual
including Repair Parts and Special Tools Lists
SEARCHLIGHT SET, INFRARED AN/VSS-3A
(NSN 5855-00-177-3529) (NSN 5855-00-405-0404)**

TM 11-5855-217-12-1, 2 July 1970, is changed as follows:

1. New or changed material is indicated by a vertical bar in the margin.
2. Remove old pages and insert new pages as indicated below.

Remove page

1-1 and 1-2

Insert page

.....1.1 and 1-2

3. File this change sheet in front of the publication for reference purposes.

By Order of the Secretary of the Army:

Official:

J. C. PENNINGTON
*Major General, United States Army
The Adjutant General*

E. C. MEYER
*General, United States Army
Chief of Staff*

DISTRIBUTION:

Active Army:

HISA (Ft Monmouth) (21)
 USAINSCOM (2)
 COE (1)
 TSG (1)
 USAARENBD (1)
 DARCOM (1)
 TRADOC (2)
 OS MAJ COMD (4)
 TECOM (2)
 USACC (4)
 MDW (1)
 Armies (2)
 Corps (2)
 Svc Colleges (1)
 USASIGS (5)
 USAADS (2)
 USAFAS (2)
 USAARMS (2)
 USASIS (2)

USAES (2)
 USAICS (3)
 MAAG (1)
 USARMIS (1)
 USAERDAA (1)
 USAERDAW (1)
 Ft Carson (5)
 Ft Gillem (10)
 Ft Gordon (10)
 Ft Richardson (CERCOM Ofc) (2)
 Army Dep (1) except
 SAAD (30)
 SHAD (2)
 TOAD (14)
 USA Dep (1)
 Sig Sec USA Dep (1)
 Units org under fol TOE:
 29-207 (2)
 29-610 (2)

NG: State AG (3) Units — SAME AS ACTIVE ARMY EXCEPT ALLOWANCE IS ONE COPY PER UNIT.

USAR: None

For explanation of abbreviations used, see AR 310-50.

WARNING

Do not direct searchlight at personnel closer than 320 meters or permanent eye damage can be inflicted. Do not look into the searchlight beam in either the visible or infrared modes. Even momentary viewing can produce permanent eye damage if closer than 320 meters and staring can be harmful up to 3,000 meters. temporary flash blindness may occur at ranges exceeding 3,000 meters.

Do not look into the searchlight beam with magnifying optical elements such as binoculars.

Dangerous voltages are present in the searchlight at the following locations:

Xenon lamp electrodes	30,000 volts
Igniter transformer	30,000 volts
Spark gap	6,000 volts
Interstage transformer	6,000 volts
Converter transformer	100 volts
Capacitors C1, C2, and C3	100 volts

Do not operate the searchlight if the blower motor does not run, or turn off the vehicle power source until the blower motor stops. The blower motor cools the Xenon lamp to prevent explosion and injuries.

Do not touch the quartz envelope of the Xenon lamp with bare hands. Dirt and finger acids can erode the quartz envelope, and the lamp may explode during operation due to the weakened envelope.

Exercise extreme caution when handling the high-pressure Xenon lamp. Always transport and handle the lamp in the lampholder, and avoid jarring or shocking the lampholder. During installation of this equipment, conform to all safety requirements set forth in TB SIG 291. Injury or DEATH can result from failure to comply with safe practices.

Installation of the searchlight is a two-man operation. Failure to use two men to install the searchlight could result in dropping or severe jarring of the searchlight, with subsequent damage to the equipment, or possible serious injury or DEATH to personnel.

Installation of the control box is a two-man operation. Failure to use two men to install the control box could result in serious injury to personnel.

Make sure the vehicle power source supplying power to the searchlight set is turned off before performing the interunit cabling procedure.

Turn the searchlight power switch OFF if OVER TEMP indicator lights. Continued operation of the searchlight when high temperature is indicated can cause Xenon lamp explosion, resulting in damage to the searchlight and possible serious injury to personnel.

Operator and Organizational
 Maintenance Manual
 Including Repair Parts and Special Tool Lists

SEARCHLIGHT SET, INFRARED/AN/VSS-3A
 FSN 5855-177-3529
 FSN 5855-405-0404

	Paragraph	Page
CHAPTER 1. INTRODUCTION		
Section I. Description and data	1-1—1-3	1-1
II. General-----	1-4—1-10	1-1—1-3
CHAPTER 2. INSTALLATION		
Section I. Service upon receipt of equipment	2-1,2-2	2-1
II. Installation procedures	2-3—2-10	2-3-2-5
CHAPTER 3. OPERATING INSTRUCTIONS		
Section I. Operators controls and indicators	3-1—3-3	3-1,3-2
II. Operation under usual conditions	3-4—3-10	3-2—3-4
III. Operation under unusual conditions	3-11—3-15	3-4,3-5
CHAPTER 4. OPERATOR'S MAINTENANCE		
Section I. General	4-1,4-2	4-1
II. Operator's preventive maintenance	4-3—4-5	4-1
III. Operator's maintenance	4-6—4-8	4-2,4-3
CHAPTER 5. ORGANIZATIONAL MAINTENANCE		
Section I. General	5-1, 5-2	5-1
II. Organizational preventive maintenance	5-3—5-5	5-1,5-2
III. Organizational troubleshooting and repairs	5-6—5-17	5-3—5-7.1
CHAPTER 6. SHIPMENT, LIMITED STORAGE, AND DEMOLITION TO PREVENT ENEMY USE		
Section I. Dissassembly and repackaging of equipment	6-1—6-3	6-1
II. Demolition to prevent enemy use	6-4-6-7	6-1,6-2
APPENDIX A. REFERENCES		A-1
B. BASIC ISSUE ITEMS		B-1
C. MAINTENANCE ALLOCATION		C-1
D. ORGANIZATIONAL REPAIR PARTS, FOR FSN 5855-177-3529		D-1
E. ORGANIZATIONAL REPAIR PARTS, FOR FSN 5855-405-0404		E-1
INDEX		I-1

LIST OF ILLUSTRATIONS

Figure	Title	
1-1	Searchlight Set, Infrared AN/VSS-3A, FSN 5855-177-3529	ii
1-2	Searchlight Set, Infrared AN/VSS-3A, FSN 5855-405-0404	iii
2-1	Packing of Searchlight	2-2
2-2	Outline and mounting dimensions	2-4
2-3	Interunit cabling diagram	2-5
3-1	Control box, Controls and indicators (C-7905A/VSS-3)	3-5
3-1.1	Control, Searchlight Set C-7905B/VSS-3, Controls and Indicators	3-5
3-2	Remote Control Box, Controls and Indicators	3-6
4-1	Heat Exchanger, RearView	4-3
5-1	Replacement of Indicator Lamps and Fuses	5-5
5-2	Replacement of Front Window and Xenon Lamp	5-6

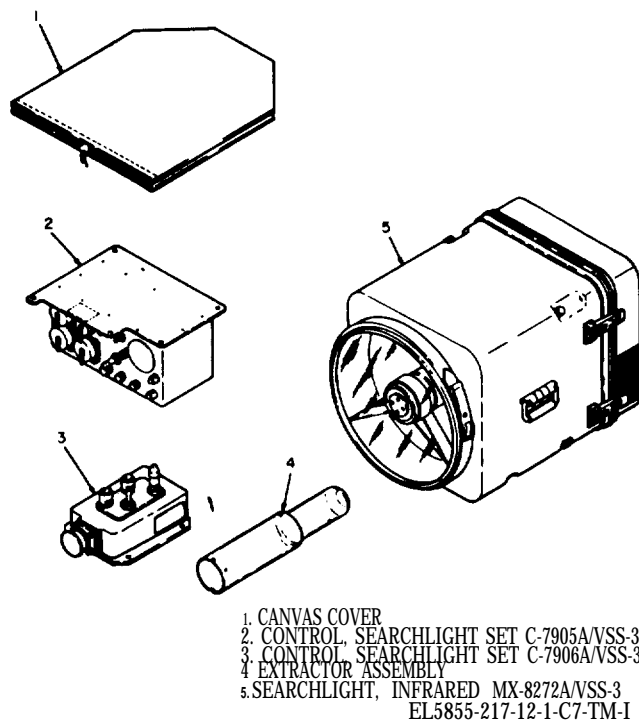
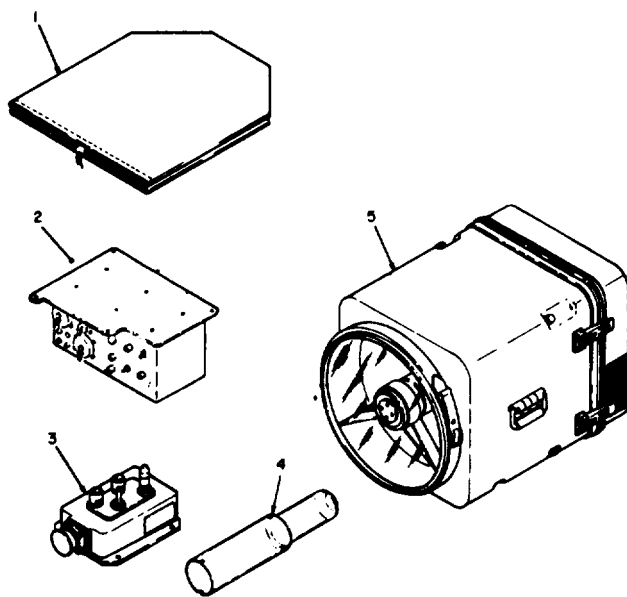

Figure 1-1. Searchlight Set, Infrared AN/VSS-3A, FSN 5855-177-3529.



1. CANVAS COVER
 2. CONTROL, SEARCHLIGHT SET C-7905B/VSS-3
 3. CONTROL, SEARCHLIGHT SET C-7906B/VSS-3
 4. EXTRACTOR ASSEMBLY
 5. SEARCHLIGHT, INFRARED MX-8272B/VSS-3
- EL5855-217-12-1-C7-TM-1.1

Figure 1-2. Searchlight Set, Infrared AN/VSS-3A, FSN 585-405-0404.

**CHAPTER 1
INTRODUCTION**

Section I. GENERAL

1-1. Scope

a. This manual describes Searchlight Set, Infrared AN/VSS-3A NSN 5855-00-177-3529 or 5855-00-405-0404 and covers its installation and operation, and operator and organizational maintenance. It includes operation under usual and unusual conditions, cleaning and inspection of the equipment, and replacement of parts available to operator and organizational maintenance personnel.

b. Appendix A contains a list of publications applicable to the equipment, appendix B contains the basic issue items list, appendix C contains the maintenance allocation chart, and appendices D and E contain the organizational repair parts.

NOTE

Appendices B, C, D, and E are current as of 25 June 1975.

c. Official nomenclature followed by (*) is used to indicate all models of equipment.

1-2. Indexes of Publications

a. *DA Pam 310-4.* Refer to the latest issue of DA Pam 310-4 to determine whether there are new editions, changes, or additional publications pertaining to the equipment.

b. *DA Pam 310-7.* Refer to DA Pam 310-7 to determine whether there are modification work orders (MWO's) pertaining to the equipment.

1-3. Forms and Records

a. *Reports of Maintenance and Unsatisfactory Equipment.* Maintenance forms, records, and reports which are to be used by maintenance personnel at all maintenance levels are listed in and prescribed by TM 38-750.

b. *Report of Packaging and Handling Deficiencies.* Fill out and forward SF 364 (Report of Discrepancy (ROD) as prescribed in AR 735-11-2/DLAR 4140.55/NAVMATINST 4355.73/AFR 400-54 and MCO 4430.3E.

c. *Discrepancy in Shipment Report (D ISREP) (SF 361).* Fill out and forward Discrepancy in Shipment Report (DISREP) (SF 361) as prescribed in AR 55-38/NAVSUPINST 4610.33B/AFR 75-18/MCO P4610.19C, and DSAR 4500.15.

1-3.1. Reporting of Equipment Publication Improvements

The reporting of errors, omissions, and recommendations for improving this publication by the individual user is encouraged. Reports should be submitted on DA Form 2028 (Recommended Changes to Publications and Blank Forms) and forward directly to Commander, US Army Electronics Command, ATTN: DRSEL-MA-Q, Fort Monmouth, NJ 07703.

1-3.2. Reporting Equipment Improvement Recommendations (EIR)

EIR's will be prepared using DA Form 2407 (Maintenance Request). Instructions for preparing EIR's are provided in TM 38-750, The Army Maintenance Management System. EIR's should be mailed direct to Commander, US Army Electronics Command, ATTN: DRSEL-MA-Q, Fort Monmouth, NJ 07703. A reply will be furnished direct to you.

1-3.3. Hand Receipt

Hand receipts for End Item/Components of End Item (COEI), Basic Issue Items (BII), and Additional Authorized List (AAL) items are published in a Hand Receipt Manual. The Hand Receipt Manual numerical designation is the same as the related Technical Manual with the letters HR added to the number. These manuals are published to aid in property accountability and are available through: Commander, US Army Adjutant General Publication Center, ATTN: AGDL-OD, 1655 Woodson Road, St. Louis, MO 63114.

Section II. DESCRIPTION AND DATA

1-4. Purpose and Use

The AN/VSS-3A is a lightweight, Xenon searchlight providing a high intensity variable beam width, visible or infrared light. It is a watertight, weather resistant, vehicle mounted searchlight used to illuminate battlefield and other tactical areas during nighttime operations.

1-5. Technical Characteristics

Type of light Visible or infrared
 Type of lamp Xenon, short arc, 1.0 kilowatt
 Output candlepower50 million minimum
 Beam width:
 Compact1.0°±0.5°
 Variable1.0° to 7.0°

Input power requirements:

Voltage 22 to 28 vdc (24 to 28 vdc for
(MX-8272B/VSS-3)
Current 58 amperes maximum
Power 1.6 kilowatts minimum

Mode of operation:

Visible light Compact, spread or variable beam
width.

Infrared light Compact, spread or variable beam
width.
Cooling system Air-to-air heat exchanger using
integral intake exhaust blower.
Reflective system Metal parabolic mirror
Focus-defocus method Motor driven
Searchlight control Provided by control box and remote
control box.

1-6. Items Comprising an Operable Searchlight Set, Infrared AN/VSS-3A, NSN 5855-00-177-3529

<i>NSN</i>	<i>ITEM</i>	<i>Quantity</i>	<i>Weight (lb)</i>
5855-00-177-3528	Searchlight, Infrared MX-8272A/VSS-3	1	62
5855-00-177-3525	Control, Searchlight Set C-7905A/VSS-3	1	2 3 1/2
5855-00-177-3527	Control, Searchlight Set C-7906A/VSS-3	1	1 1/2

1-6.1. Items Comprising an Operable Searchlight Set, Infrared AN/VSS3A, NSN 5855-00-405-0404

<i>NSN</i>	<i>ITEM</i>	<i>Quantity</i>	<i>Weight (lb)</i>
5855-00-189-6066	Searchlight, Infrared MX-8272B/VSS-3	1	62
5855-00-189-6065	Control, Searchlight Set C-7905B/VSS-3	1	2 3 1/2
5855-00-451-5224	Control, Searchlight Set C-7906/VSS-3	1	1 1/2

Note. The items comprising AN/VSS-3A, NSN 5855-00-177-3529 are interchangeable with items comprising AN/VSS-3A, NSN 5855-00-405-0404.

1-6.2. Installation Kits

The following installation kits must be requisitioned separately

a. Installation Kit M551.

<i>NSN</i>	<i>ITEM</i>	<i>Quantity</i>
5855-00-114-4949	Installation Kit, M551 consisting of	1
5855-00-135-0162	Searchlight support	1
5810-00-767-9425	Flat washer	4
5305-00-716-8186	Cap screw	4
5855-00-110-3541	Quick disconnect pin	3
5996-00-135-0081	Cable Assembly, Power, Electrical CX-11893/VSS-3	1
5305-00-052-6456	Screw cap,	4
5310-00-721-7809	Washer, lock	4
5305-00-269-2803	Screw, cap, hexagon	4
5310-00-061-1258	Washer, lock	4

b. Installation Kit M60.

<i>NSN</i>	<i>ITEM</i>	<i>Quantity</i>
5855-00-114-4953	Installation kit, M60 consisting of	1
5855-00-1144954	Searchlight mount assembly	1
5310-00-767-9425	Flat washer	4
5305-00-725-4183	Cap screw	4
5995-00-177-3562	Cable Assembly, Power, Electrical (SC-D-647380)	1
5310-00-004-5033	Washer, lock	4
5305-00-269-3209	Screw cap	4
5310-00-891-1749	Nut, hex	4
5305-00-995-3444	Screw, pan head	4
5310-00-045-3296	Washer, lock	4
5310-00-809-8546	Washer, flat	4

1-7. Common Names

A list of common name assignments for components of searchlight set is given below

<i>Common name</i>	<i>Nomenclature</i>
Control box	Control Searchlight Set C-7905 (*)/VSS-3
Remote control box	Control, searchlight set C- 7906(*)/VSS-3

<i>Common name</i>	<i>Nomenclature</i>
Power cable	Cable, Assembly, Power, Electrical CX-11893/VSS-3
Beam switch	COMPACT-SPREAD BEAM switch
Control Switch	LOCAL-REMOTE switch

Common name	Nomenclature
Power switch	OFF-INFRARED-VISIBLE switch
Searchlight	Searchlight, Infrared MX-8272(*)/VSS-3
Searchlight set	Searchlight Set, Infrared AN/VSS-3A
Canvas cover	Searchlight cover

1-8. Description of Equipment
(fig. 1-1, 1-2)

CAUTION

The components of this searchlight are not compatible with any other equipment except that which is covered in this manual. If a VSS-3 searchlight sub-assembly is connected to a VSS-3A control box, the booster-starter module will burn out. If a VSS-3A searchlight sub-assembly is connected to a VSS-3 control box, the searchlight will not operate but no damage will occur.

Searchlight Set, Infrared AN/VSS-3A consists of three major components. The three components are the searchlight, the control box, and the remote control box. Mounting hardware is part of the installation kit (para 1-6.2).

a. *Searchlight, Infrared MX-8272(*)/VSS-3.* This unit contains the greater part of the searchlight set components and protects the internal components from physical damage and exposure to dust and moisture. The searchlight consists of the main support assembly, searchlight housing, heat exchanger, window, and window clamp. The searchlight is attached to the searchlight support by means of mounting hardware.

(1) *Searchlight main support assembly.* This assembly consists of the main support assembly, reflector, Xenon lamp, IR filter, diode CR 1, transformers, spark gap assembly, terminal board TB1, filter drive motor, focus-defocus motor, elapsed time indicator and shock mounts. Low voltages (28 volts dc) from the vehicle power source is converted to a high voltage (30 kv) for ignition of the Xenon lamp. After the lamp is ignited, the 28 volts dc is used to maintain lamp illumination. The light produced by the Xenon lamp is concentrated and shaped by the reflector. Mechanical controls are used to position the IR filter over the Xenon lamp for IR illumination.

(2) *Searchlight housing.* The searchlight housing is a pressed aluminum shell fitted with carrying handles, latches, and an electrical receptacle. The housing contains the searchlight main support assembly which is attached to it by shock mounts.

(3) *Heat exchanger.* The heat exchanger is at-

tached to the rear of the searchlight housing and electrically connected to the main support assembly. This unit contains the blower motor, with intake and exhaust fans, ballast resistor, and the rear cover to which air ducts and cooling fins are attached.

(4) *Window and window clamp.* The window is sealed and attached to the searchlight housing by the window seal and window (grooved) clamp. The window provides protection against dust and moisture.

b. *Control, Searchlight Set C-7905(*)/VSS-3.* The control box contains the necessary switches and indicators for operating, monitoring operation, and troubleshooting the searchlight. It is mounted within the tank and consists of a housing and a mounting plate.

(1) The housing contains the control, power, and beam switches used to control searchlight operation, the CIRCUIT TEST switch and indicator used for troubleshooting, and the OVER TEMP and LAMP ON indicators used to monitor searchlight operation. Also, the housing contains receptacles for power and intercomponent connections.

(2) The mounting plate attached to the housing is used to mount the control box within the vehicle.

c. *Control, Searchlight Set C-7906(*)/VSS-3.* The remote control box contains the necessary switches and indicators for operating and monitoring the operation of the searchlight from the remote position. It is mounted within the vehicle and consists of a housing and a mounting plate.

(1) The housing contains the control, power, and beam switches used to control the operation of the searchlight. Also, the housing contains the OVER TEMP and LAMP ON indicators and a receptacle for connection to the control box.

(2) The mounting plate attached to the panel housing is used to mount the remote control box within the vehicle.

1-9. Description of Minor Components
(fig. 1-1, 1-2)

Accessories included in the searchlight set are the extractor assembly and the searchlight cover. The searchlight cover is a canvas cover used to protect the searchlight when the equipment is not in operation. The portion which covers the window contains a stiffener to protect the glass. The extractor assembly is used when removing the Xenon lamp.

1-10. Additional Equipment Required

The following equipment is not supplied as a part of the searchlight set, but is required for its operation:

TM 11-5855-217-12-1

<i>Equipment</i>	<i>Purpose</i>	<i>Equipment</i>	<i>Purpose</i>
Source of 28vdc, 58 amperes minimum.	Supply dc power to the searchlight.	Searchlight power cable (supplied by vehicular maintenance).	Connects the control box to the vehicle receptacle.
DC input power cable (supplied by vehicular maintenance).	Connect external power to the control box.	Remote control box cable (supplied by vehicular maintenance).	Connects the remote control box to the control box.

CHAPTER 2 INSTALLATION

WARNING

During installation of this equipment, conform to all safety requirements set forth in TB SIG 291. Injury or DEATH can result from failure to comply with safe practices.

Section I. SERVICE UPON RECEIPT OF EQUIPMENT

2-1. Unpacking

(fig. 2-1)

a. Packaging Data. When packed for shipment, Searchlight Set, Infrared AN/VSS-3A is packed in a wooden shipping container divided into two compartments. One compartment contains the searchlight, and the other compartment contains a box holding the remainder of the searchlight set components.

WARNING

Removing the searchlight is a two-man operation. Failure to use two men to remove the searchlight could result in dropping the searchlight, with subsequent possible damage to the equipment or injury to personnel.

CAUTION

Use care in removing the lid of the shipping container and the searchlight set components to avoid damaging them.

b. Removing Contents. Pry off the top of the shipping container with a crowbar or similar tool. Remove the packing material and lift out the searchlight. Remove the box containing the remainder of the searchlight set components.

2-2. Checking Unpacked Equipment

a. Inspect the searchlight set for damage that

may have occurred during shipment. If the equipment has been damaged, report the damage on DD Form 6 (para 1-3).

b. Check to see that the searchlight set is complete as listed on the packing slip. If a packing slip is not available, check the equipment against paragraph 1-6 or 1-6.1. Report all discrepancies in accordance with TM 38-750. The equipment should be placed in service even though a minor assembly or part that does not affect proper functioning is missing.

c. Check to see whether the equipment has been modified. If the equipment has been modified, the MWO number will appear on the front panel near the nomenclature plate. Check also to see whether all MWO's current at the time the equipment has been placed in use have been applied. Refer to DA Pam 310-7.

NOTE

Current MWO's applicable to the equipment are listed in DA Pam 310-7.

d. Check the latest issue of DA Pam 310-4 (never more than 1 year old) and its latest changes (never more than 6 months old) to see whether you have the latest editions of all applicable maintenance literature. Equipment issued by depots may have been in stock for some time and may contain superseded manuals.

NOTE

Included in the packing case is TM 11-5855-217-12-2 (envelope) containing caution decals and installation instructions. Decals should be applied as soon as the Searchlight and Control Box are mounted.

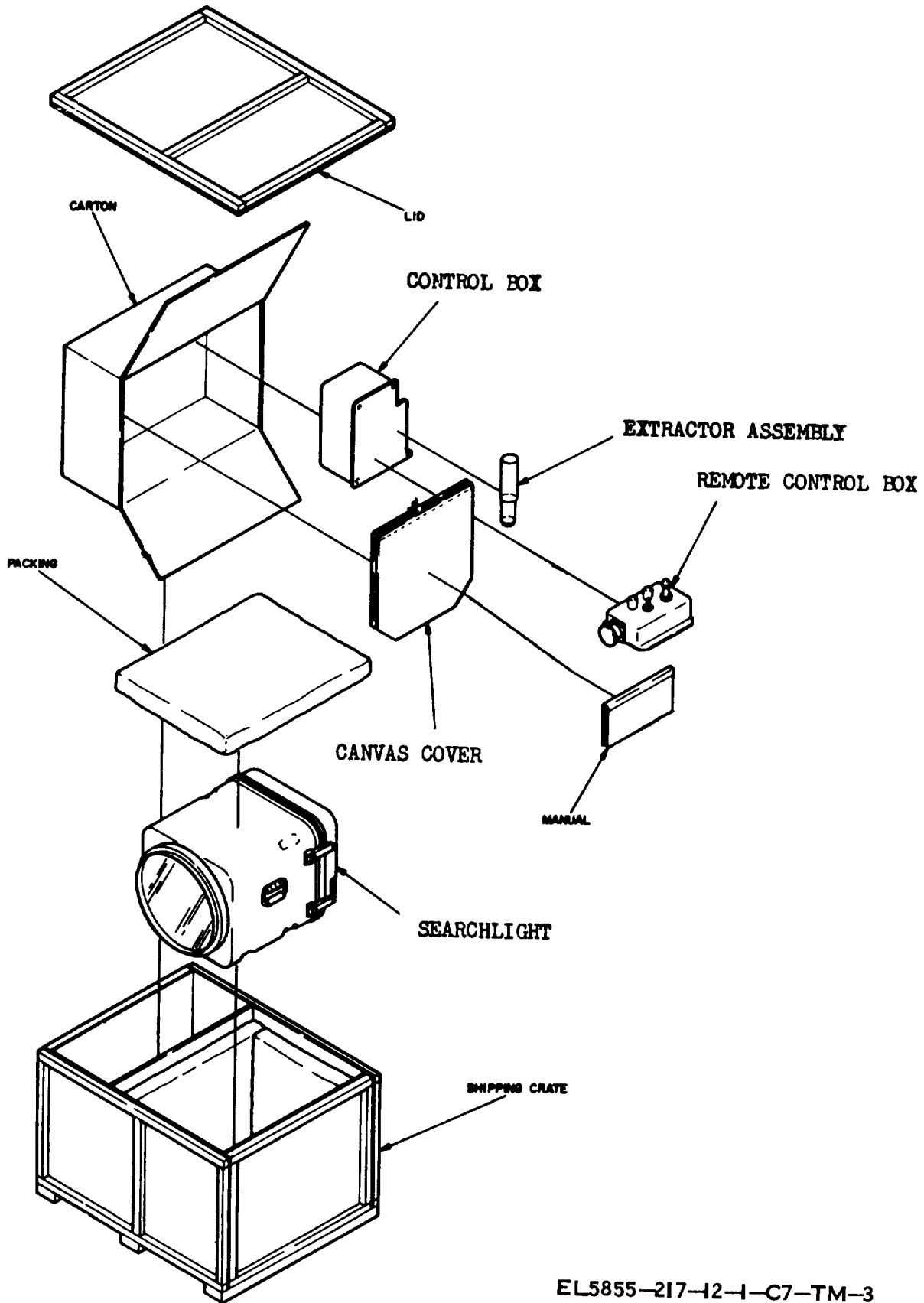

EL5855-217-12-1-C7-TM-3

Figure 2-1. Packing of Searchlight.

Section II. INSTALLATION PROCEDURES

NOTE

The following assembly and installation procedures must be made by organizational support, or higher level maintenance personnel.

2-3. Tools, Test Equipment, and Materials Required for Installation

No test equipment or materials are required for installation of the searchlight set. The following tools are required for installation.

<i>Item</i>	<i>Purpose</i>
Toolkit, TK 100G..	Installation of searchlight

2-4. Assembly of Component Items

(fig. 2-2)

WARNING

The Xenon lamp is filled with gas under high pressure. Be extremely careful in handling the searchlight. Jarring or severe shocks could cause the lamp to explode, resulting in damage to the equipment, and possible serious injury or DEATH to personnel.

CAUTION

Prior to first time installation of a searchlight on a vehicle, check the polarity of the input power. Input power connections must be +28 volts dc on pin A of the input power cable and common at pin B.

a. The searchlight set is installed on a platform on Armored Reconnaissance/Airborne Assault Vehicle M551, Installation Kit M551 is required for installing the searchlight set on the M551.

b. The searchlight set is installed on the gun turret of Tank, Combat, Full Tracked M60. Installation Kit M60 is required for installing the searchlight on the M60.

c. Make sure that you have the proper installation kit as described in paragraph 1-6.2.

2-5. Installation of Searchlight on M551

WARNING

The Xenon lamp is filled with gas under high pressure. Be extremely careful in handling the searchlight. Jarring or severe shocks could cause the lamp to explode, resulting in damage to the equipment, and possible serious injury or DEATH to personnel.

To attach the support to the searchlight, perform the following procedures:

a. Set the searchlight down with the front of the searchlight pointing in the vertical direction.

b. Align the four holes in the support (fig. E-3) with the four mounting holes in the bottom of the housing.

c. Put a washer and mounting screw in each mounting hole and tighten each screw loosely.

d. Align the support with the searchlight and

tighten the screws.

e. The searchlight is installed on the mounting platform using the three quick-release pins in the installation kit. To install the searchlight, perform the following procedures:

(1) Lower the searchlight onto the mounting platform and insert the two rear legs of the support into the mounting platform ears.

(2) Align the holes in the support with the holes in the mounting platform and insert, but do not tighten, two quick-release pins.

(3) Lower the front of the searchlight until the hole in the front leg of the support is aligned with the hole in the front of the mounting platform.

(4) Insert a quick-release pin.

(5) Tighten all three pins.

2-5.1. Installation of Searchlight on M60

(fig. 2-2,2-3, and E-4)

WARNING

Installation of the searchlight is a two-man operation. Failure to use two men to install the searchlight could result in dropping or severe jarring of the searchlight, with subsequent damage to the equipment or possible injury or DEATH to personnel.

a. Align the four holes in M60 mount assembly with four mounting holes in bottom of searchlight.

b. Use four washer and cap screws to secure searchlight to M60 mount assembly.

c. With ball latches unlocked, lift searchlight and position searchlight ball sockets on three ball studs on gun shield.

d. Lock ball latches by depressing hitch handles.

2-6. Installation of Control Box

(fig. 2-2)

WARNING

Installation of the control box is a two-man operation. Failure to use two men to install the control box could result in serious injury to personnel.

To install the Control Box, perform the following procedures:

a. Position the control box mounting plate over the four control box mounting holes in the vehicle.

b. Put a lockwasher over each of four screws.

c. Insert a screw in each mounting hole and tighten.

2-7. Installation of Remote Control Box

(fig. 2-2)

Use the following procedures in installing the remote control box:

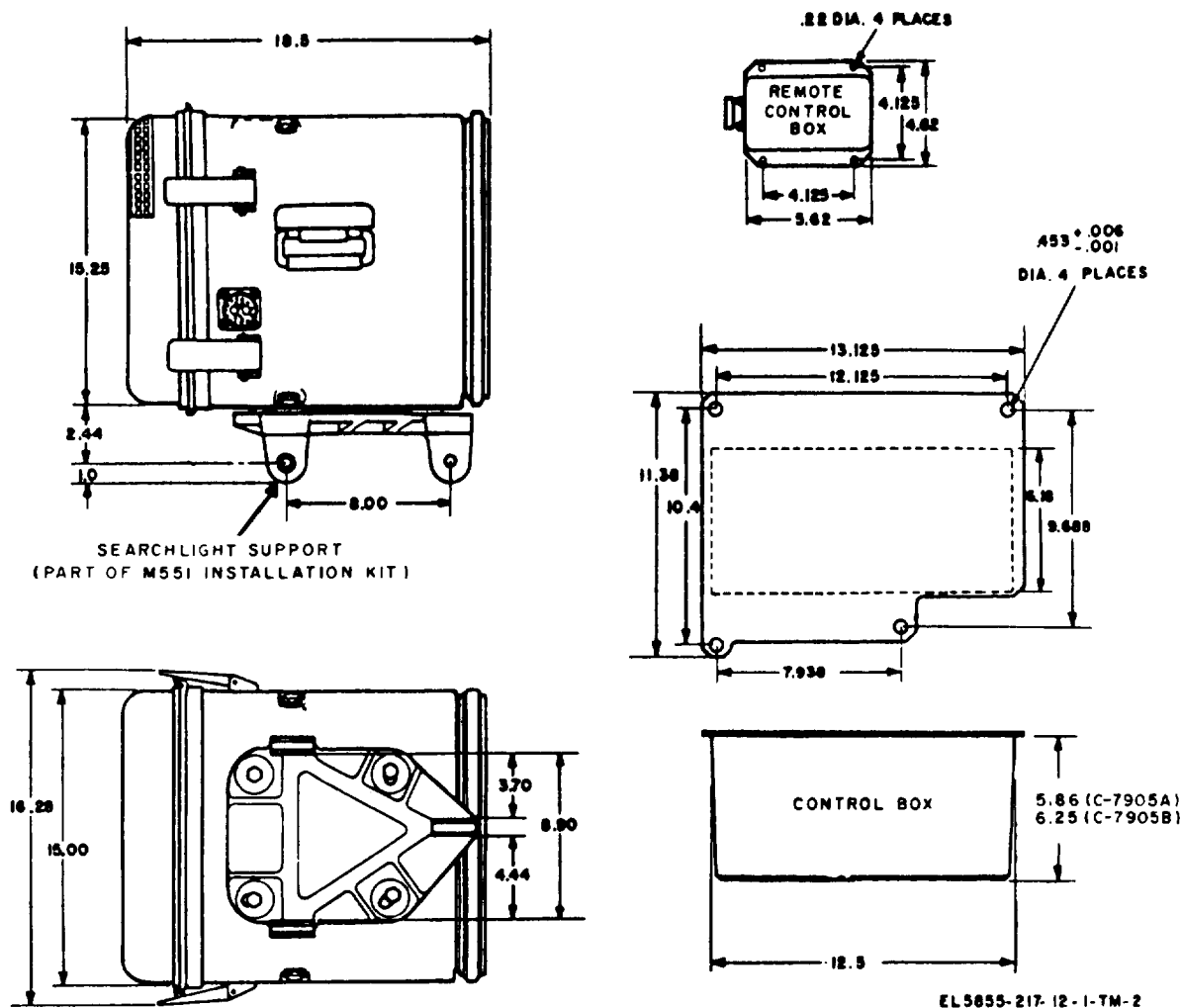

Figure 2-2. Outline and mounting dimensions.

- a. Position the mounting holes in the remote control box mounting plate over the four mounting holes in the vehicle.
- b. Put a lockwasher over each of the four mounting screws.
- c. Insert a mounting screw in each hole and tighten.

2-8. Interunit Cabling

(fig. 2-3)

WARNING

Make sure that the power source applying power to the searchlight set is turned off before performing the interunit cabling procedure.

Perform interunit cabling of the searchlight in the following order:

- a. Power cable (1) from searchlight to vehicle receptacle.
- b. Power cable (2) from vehicle receptacle to control box.
- c. Remote control box cable (3) from remote control box J 1 to control box J2.
- d. Input power cable (4) from vehicle power source to J 1 on control box.

2-9. Initial Checks and Adjustments

Perform the following checks and adjustments before operating the searchlight set.

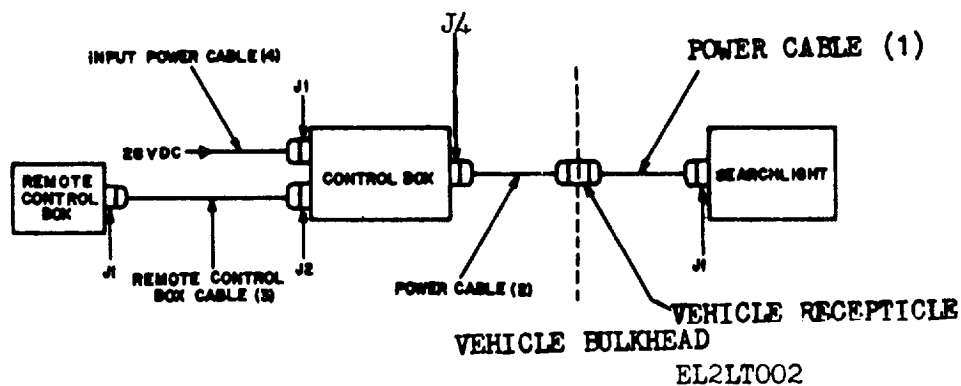

Figure 2-3. Interunit cabling diagram.

- a. Check that the Xenon lamp is installed.
- b. Set the CIRCUIT TEST switch on the control box to the OPERATING POSITION.
- c. Set the power switches on both the control box and the remote control box to OFF.
- d. Set the control switch on the control box to LOCAL.
- e. Check that proper MOTOR and auxiliary B + fuses are installed in the control box. See paragraph 6-8 for fuse ratings.
- f. Check all mounting screws for tightness.

g. Check all cable connections *for* tightness and proper fit.

h. Check that interunit cabling is proper and complete.

j. Check air intake and exhaust ducts (fig 4-1) to be sure they are clear and free of obstructions.

2-10. Servicing

Perform the operator's preventive maintenance checks and services (para 4-4). When the tests are completed, report the equipment ready for operation.

CHAPTER 3
OPERATING INSTRUCTIONS

Section I. OPERATORS CONTROLS AND INDICATORS

WARNING

Before operating this equipment, make sure that all requirements of TB SIG 291 are met, Injury or DEATH could result from improper or careless operation.

3-1. Searchlight Controls

(figs. 3-1 and 3-2)

<i>Control</i>	<i>Function</i>
COMPACT BEAM-SPREAD BEAM (beam switch).	COMPACT BEAM (down) position—searchlight produces a narrow light beam. SPREAD BEAM (up) position (springloaded) spreads beam from 1.0° compact to full spread at 7.0°. Approximately 2 seconds is required for full beam expansion. To hold beam at any width between two extremes, release beam switch and allow it to return to center position.
OFF-INFRARED-VISIBLE (power switch).	NOTE Center position is off position for focus motor. Holds beam width fixed while beam switch is at SPREAD BEAM. OFF (down) position—turns off power to set and returns searchlight to infrared mode. INFRARED (middle) position—places searchlight in infrared operating mode. VISIBLE (up) position—places searchlight in visible operating mode.
CIRCUIT TEST switch _____	OPERATING POSITION—normal position for operating searchlight. Position 2-tests for input voltage level at 22 volts dc minimum. Position 3-tests B+ to sense board. Position 4-tests blocking diode CR1 for continuity. Position 5-tests for application of 22 to 28 volts dc to blower motor. Position 6-tests lamphouse connector for continuity. Position 7—tests input voltage and power relay K1 operation.

Control
 LOCAL-REMOTE
 (control switch).

Function
 LOCAL position—switches control of searchlight to control box.
 REMOTE position—switches control of searchlight to remote control box.

3-2. Searchlight Indicators
 (figs. 3-1 and 3-2)

Indicator
 OVER TEMP indicator
 LAMP ON indicator
 CIRCUIT TEST indicator

Function
 Indicates when searchlight is overheated. Turns on at 400° F and turns off at 380 °F.
 Indicates when searchlight Xenon lamp is on by lighting.
 With CIRCUIT TEST switch in OPERATING Position, allows normal operation of the searchlight.
 With CIRCUIT TEST switch in positions 2 through 7, indicates malfunction in circuit under test by not lighting.

3-3. Variation of Indicator Lamp Brightness

The brightness of all indicator lamps is varied through a grating arrangement in the body of the indicator. To vary lamp brightness, turn the body of the lamp as indicated.

a. To dim the lamp, turn the body of the lamp clockwise.
 b. To brighten the lamp, turn the body of the lamp counterclockwise.

Section II. OPERATION UNDER USUAL CONDITIONS

3-4. Heat Exchanger
 (figs. 4-1, 5-2)

WARNING

Do not attempt any cleaning procedures while the searchlight is operating. The searchlight uses high voltages and current for operation which can cause serious injury.

The air intake and exhaust ducts on the heat exchanger must be free from obstructions before the equipment is operated. If necessary, flush water through air ducts to remove any dirt, insects, or other foreign matter which may restrict air circulation.

3-5. Preliminary Control Settings
 (figs. 3-1 and 3-2)

The searchlight set may be operated in the spread, compact, or variable beam mode of operation. The

preliminary control settings and the starting procedures are the same for all types of operation. Before starting the equipment (para 3-6), check the setting of the operating controls as follows:

<i>Control</i>	<i>Position</i>
Power switch	OFF
CIRCUIT TEST switch	OPERATING POSITION
Control switch	LOCAL

3-6. Starting Procedure
 (figs. 3-1 and 3-2)

NOTE

If an abnormal result is obtained during the starting procedure, refer to the operational checks (para 4- 5, sequence Nos. 9 through 11). Refer to paragraph 3-4 before starting the equipment.

a. Start the vehicle power source.

WARNING

1. Do not look directly into the searchlight beam. Blindness or serious eye damage may result.
2. Do not operate the searchlight in the compact beam visible mode while personnel are within 320 meters of the beam path.
3. Personnel may suffer temporary flash blindness at ranges in excess of 320 meters when the searchlight is operated in either the compact or spread beam visible mode.
4. Do not operate the searchlight if the exhaust blower does not operate.

b. Set the power switch to either the INFRARED or VISIBLE position; depending on the mode of operation required. The Xenon lamp will ignite within 3 seconds, the exhaust blower will operate, the LAMP ON indicator will light, and the CIRCUIT TEST indicator does not light.

c. If the Xenon lamp does not ignite, set the power switch to OFF and repeat the starting procedure. Do not try to ignite the Xenon lamp after five or six attempts have been made.

d. Check the air intake and exhaust ducts (fig. 4-1) for airflow to make certain that the blower motor is operating.

e. After 1 minute of Xenon lamp operation, check to see that the OVER TEMP indicator is not lighted. Improper cooling of the searchlight will cause the OVER TEMP indicator to light.

CAUTION

Periodically check the OVER TEMP indicator during searchlight operation. The searchlight set will continue to operate even if an overheated condition exists. It is the responsibility of the operator to turn off the searchlight set if the OVER TEMP indicator lights.

3-7. Beam Width Adjustments

(figs. 3-1 and 3-2)

To adjust the beam width, start the searchlight set as described in paragraph 3-5, and proceed as follows:

a. *Compact Beam Operation.* Place the beam switch to the COMPACT BEAM position. The searchlight beam width will automatically be adjusted until the narrowest beam width of approximately 1.0° is projected from the searchlight.

b. *Spread Beam Operation.* Place the beam switch in the SPREAD BEAM position and hold until the widest beam width (7°) is projected from the searchlight.

c. *Variable Beam Operation.* A variable beam width is obtained by holding the spring-loaded beam switch in the SPREAD BEAM (up) position. The

light beam will spread from 1.0° to 7.0° beam width in 2 seconds. To hold the beam at any width between 1.0° and 7.0°, release the beam switch, allowing it to return to the center position. The beam will stay at the desired width until the beam switch is placed in either the SPREAD BEAM or COMPACT BEAM position. If the switch is returned to SPREAD BEAM position, the searchlight beam will continue to spread to 7.0°. The beam spread maybe stopped and held any number of times until the beam is fully spread to 7.0°. To return the beam to 1.0° (compact narrow beam), it is necessary to set the beam switch to the COMPACT BEAM position.

3-8. Modes of Operation

(figs. 3-1 and 3-2)

a. *Visible Mode.* Pull out on the power switch lever, move up to VISIBLE position and release.

b. *Infrared Mode.* Push the power switch lever to the INFRARED position; the switch will remain locked.

c. *Remote Control.* To control the searchlight from the remote control box, set the control box as follows:

<i>Control</i>	<i>Position</i>
Power switch	OFF
CIRCUIT TEST switch	OPERATING POSITION
Control switch	REMOTE

NOTE

If the control box power switch is at INFRARED or VISIBLE, power will be applied to the searchlight regardless of the position of the control switch on the control box .

3.9. Normal Stopping Procedure

(figs. 3-1 and 3-2)

CAUTION

Do not turn the searchlight off anywhere except at the control box or remote control box.

a. Set Control Box C7905A/VSS-3 controls as follows:

(1) Place the beam switch to COMPACT BEAM and hold for 2 seconds, to release the strain on the reflector.

(2) Set the power switch to OFF.

b. Control Box C-7905B/VSS-3, set the power switch to OFF. A relay will cause the beam to return to the compact mode and release the strain on the reflector. The Xenon lamp will turn off; the blower motor will continue to operate if the searchlight has been operating more than 5 minutes.

WARNING

To prevent Xenon lamp explosion and possible injury to personnel, wait until the

blower motor stops before continuing with the next procedure.

c. Shut off the vehicle power source.

d. Set all operating controls to the positions specified in paragraph 3-5.

3-10. Emergency Stopping Procedure

In an emergency, it maybe necessary to turn off the searchlight set in the shortest possible time. To do this, shut off the vehicle power source that supplies power to the searchlight set.

Section III. OPERATION UNDER UNUSUAL CONDITIONS

3-11. Fording

CAUTION

Do not operate the searchlight when fording through deep water.

a. The searchlight can be forded through deep water without damaging the searchlight internal components. The window clamp contains a gasket which forms a waterproof seal for the window. The heat exchanger contains a gasket which forms a waterproof seal between the heat exchanger and the searchlight housing.

b. Check to be sure that gaskets in the window damp and heat exchanger are in good condition and that the clamp and cover latches are properly closed. Water will flow into the heat exchanger through the open air intake and exhaust ducts without damaging the searchlight.

3-12. Operation in Arctic Climates

Subzero temperatures and climatic conditions associated with the cold weather affect efficient use of the equipment. Instructions and precautions for operations under such adverse conditions are as follows.

a. Frequently inspect the exterior of the searchlight and remove any accumulations of ice or snow, particularly around the window and the air intake and exhaust ducts.

b. Inspect the power cable, window clamp, and window for possible damage. Report defects to higher category of maintenance.

c. Cover the searchlight when it is not in operation.

3-13. Operation in Tropical Climates

When operated in tropical climates, moisture and humid conditions can cause problems with the searchlight. These conditions are particularly severe when the searchlight set is operated in swampy areas. Condensation of moisture on the equipment occurs frequently. To minimize the possibility of damage by moisture, take the following precautions:

a. Keep the equipment dry and clean.

b. Check all exterior parts frequently for evidence of corrosion and fungus formation.

c. Inspect the heat exchanger air intake and exhaust ducts and remove any obstructions.

d. Inspect the heat exchanger and window for a tight fit.

e. Inspect the front panels on the remote control box and control box for evidence of corrosion or fungus formation.

f. Properly tighten all electrical connectors.

g. Cover the searchlight when it is not in operation.

3-14. Operation in Desert Climates

Heat and dusty or sandy conditions are primary problems in desert areas. To minimize the possibility of damage by heat, dust, or sand, take the following precautions:

a. Remove the window or heat exchanger only when absolutely necessary.

b. Cover the searchlight with the canvas cover when the searchlight is not in operation. If possi

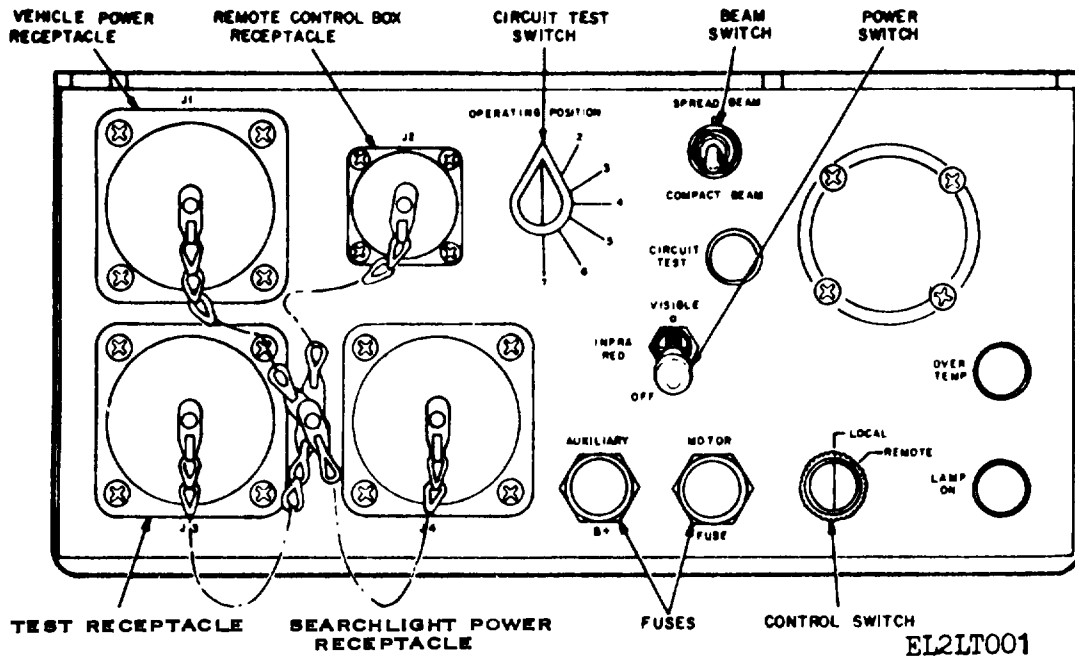
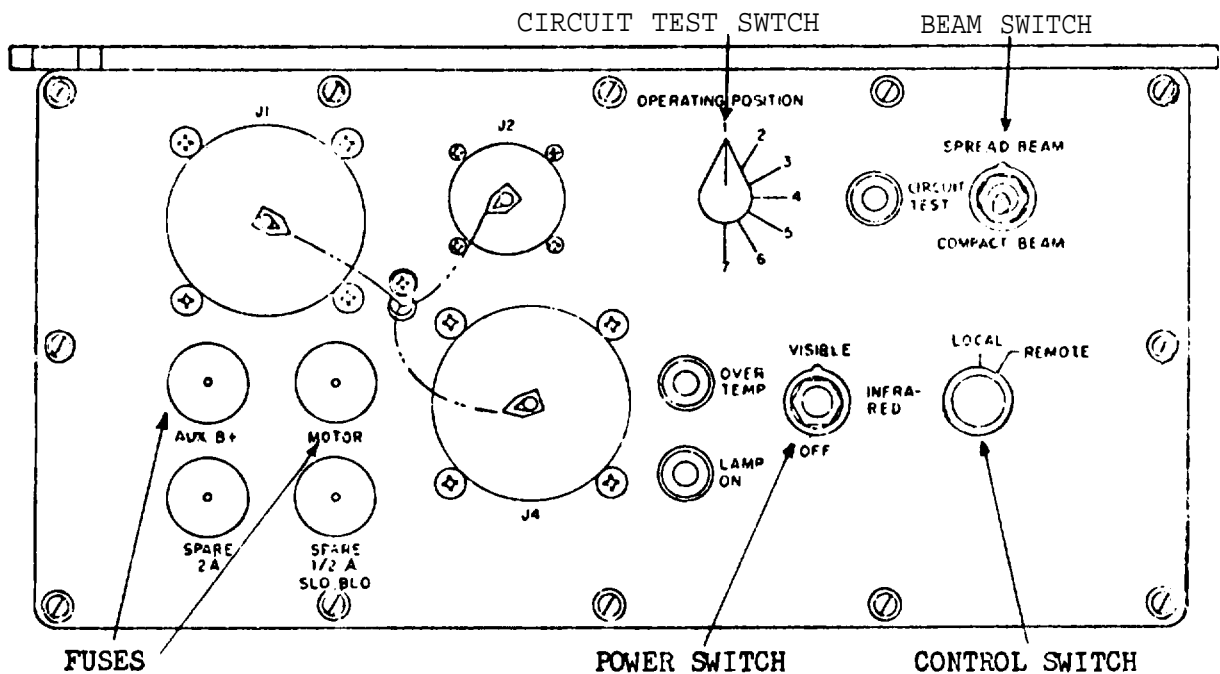

Figure 3-1. Control box(C-7905A/VSS-3), controls and indicators.



EL 5855-217-12.1-TM-53

Figure 3-1.1 Control box(C-7905B/VSS-3), controls and indicators,

ble, locate the searchlight in a sheltered area. Take advantage of any natural barrier which may offer protection from blowing dust.

c. Inspect the heat exchanger air intake and exhaust ducts. Flush the duct openings with water to remove any obstructions.

d. Keep the equipment clean.

3-15. Operation Under Salt Water Spray Environments

Instructions and precautions for operation under salt water spray conditions are as follows:

a. Protect the searchlight from salt water spray. Wash it down regularly with fresh water and wipe dry with a clean, lint free cloth.

b. If permanent shelter is not available, protect the searchlight with the canvas cover when it is not in operation. Remove the cover during dry periods and allow the searchlight to dry out.

c. Inspect all painted surfaces for cracked, peeled, or blistered paint, and report discrepancies to higher category of maintenance.

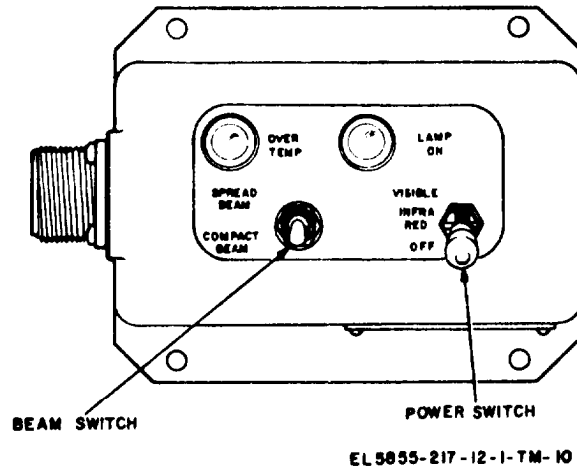

Figure 3-2. Remote control box, controls and indicator.

CHAPTER 4 OPERATOR'S MAINTENANCE

Section I. GENERAL

4-1. Scope

The maintenance duties assigned to the operator of the searchlight set are listed below together with a reference to the paragraphs covering the specific maintenance function.

- a. Operator weekly preventive maintenance checks and services (para 4-6).
- b. Cleaning (para 4-6).

c. Operator troubleshooting (para 4-8).

4-2. Tools, Test Equipment, and Materials Required

No tools or test equipment are required for operator maintenance. Materials required to clean the searchlight set are given below.

- a. Soft, clean, lint free cloth.
- b. Fresh water and mild soap.

Section II. OPERATOR'S PREVENTIVE MAINTENANCE

4-3. Preventive Maintenance

Preventive maintenance is the systematic care, servicing, and inspection of equipment to prevent the occurrence of trouble, to reduce downtime, and to assure that the equipment is serviceable.

a. *Systematic Care.* The procedures given in paragraphs 4-6 and 4-6 cover routine systematic care and cleaning essential to the proper upkeep and operation of equipment.

b. *Preventive Maintenance Checks and Services.* The preventive maintenance checks and services chart (para 4-5) outlines functions to be performed at specific intervals. These checks and services are to maintain Army electronic equipment in a combat-serviceable condition; that is, in good general (physical) condition and in good operating condition. The chart indicates what to check, how to check, and what the normal conditions are. The *References* column lists the illustra-

tions or paragraphs containing detailed checks and services procedures. If an abnormal condition is found and the defect cannot be remedied by the operator, higher category of maintenance or repair is required. Records and reports of these checks must be made in accordance with the requirements set forth in TM 38-750.

4-4. Preventive Maintenance Checks and Services Required

Preventive maintenance checks and services of the searchlight set are required weekly. Paragraph 4-5 specifies checks and services that must be accomplished weekly and under the special conditions listed below.

- a. When the equipment is initially installed.
- b. When the equipment is reinstalled after removal for any reason.
- c. At least once each week if the equipment is maintained in a standby condition.

4-5. Operator Weekly Preventive Maintenance Checks and Services Chart

Sequence No.	Item to be inspected	Procedures	References
1	Exterior surfaces	CLEAN SEARCHLIGHT AND CONTROL PANELS INSPECT DECALS FOR DAMAGE	Para 4-6
2	Heat exchanger	Clean air intake and exhaust ducts	Para 4-6
3	Window	a. Clean window b. Check glass for deep scratches or cracks.	Para 4-6
4	Reflector	a. Check for cleanliness. b. Check surface area for scratches or discoloration.	

Sequence No.	Item to be inspected	Procedure	References
5	Interconnecting cables and connectors	Check all interconnecting cables and connectors for cracks and breaks.	
6	Searchlight mount	Check attaching parts for tight connections.	
7	Searchlight	Check for cracks, dents, or other evidence of damage.	
8	Knobs and switches	While making operational checks (items 9 through 12), observe that mechanical action of each knob and switch is smooth and free of binding. Set the following knobs and switches as indicated, before proceeding to step 9. Control switch LOCAL Power switch OFF	
9	Circuit test switch	Start engine and turn vehicle power switch ON. Set to OPERATING POSITION and turn on searchlight. Note that CIRCUIT TEST indicator lamp does not light.	Para 3-6
10	Power switch	a. Set to VISIBLE: Xenon lamp will ignite within 3 seconds, exhaust blower will operate, and LAMP ON indicator will light. After approximately 1 minute of Xenon lamp operation, see that OVER TEMP indicator is not lighted. b. If Xenon lamp does not light within 3 seconds, set to OFF, and repeat procedure. Do not attempt to ignite Xenon lamp after five or six attempts have been made. c. During visible mode of operation, adjust for spread beam, and then compact beam. Note that light beam varies in width. d. Set to INFRARED. Wait a few seconds, then note that: (1) LAMP ON indicator lamp lights in infrared mode, (2) Mode of operation changes from visible to infrared.	Para 3-5 Para 3-6 Para 3-7 Para 3-8
11	Control switch	a. Set to REMOTE, Repeat sequence 10. Note that remote control box operates the searchlight. b. Set to LOCAL.	Para 3-8
12	Blower motor	Set to VISIBLE. Wait 10 minutes, and then set to OFF. Heat exchanger blower motor must continue to operate.	Para 3-8
13	Searchlight shutdown	Follow procedure given in para 3-9 to turn off searchlight. Turn vehicle power switch OFF, stop the engine.	Para 3-9

Section III. OPERATOR'S MAINTENANCE

4-6. Cleaning Procedures

(fig. 4-1)

WARNING

Make certain that the searchlight set is turned off and cool before cleaning.

a. *Exterior surfaces.* The exterior should be clean, free of dust, dirt, grease, insects and fungus.

CAUTION

Do not wash the exterior of the equipment with high-pressure hoses.

(1) Wash the exterior of the searchlight with a

LOW PRESSURE HOSE OR BY USING BUCKETS OF FRESH WATER.

(2) If dirt is difficult to remove, use a damp cloth or sponge and mild soap, then flush with fresh water,

(3) When the exterior surface contains only dust or loose dirt, wipe it with a clean soft cloth.

(4) Remove grease, fungus, and ground-in dirt from the equipment by using a cloth and soap and water. Flush exterior surfaces with low-pressure fresh water. Dry equipment with a clean, lint free cloth.

(5) REPLACE DAMAGED OR DEFACTED DECALS, SEE TM 11-5855-217-12-2.

CAUTION

Do not use any cleaning solvent or abrasive compound on the glass.

c. Searchlight Window. Clean the outside of the window with a clean, lint free cloth and fresh water. Gently wipe from the center to the outer edge. If scratched or cracked, refer to organizational maintenance.

d. Reflector. If dirty or scratched, refer to organizational maintenance.

4-7. Lubrication

No lubrication of the AN/VSS-3A is required.

4-8. Operator's Troubleshooting Chart

WARNING

Do not operate searchlight while personnel are within 320 meters of the beam path; eye damage will result.

a. Troubleshooting of this equipment by the operator is based upon the results of the operating checks sequence numbers 9 through 14 in paragraph 4-5.

b. When troubleshooting equipment, follow the operating checks until a trouble symptom is noted, then turn the CIRCUIT TEST switch to the position indicated in the *Symptom* column.

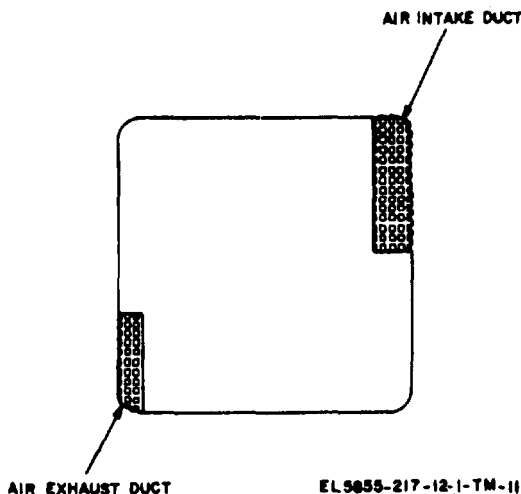

Figure 4-1. Heat exchanger, rear view.

b. Heat Exchanger. Remove foreign matter from the heat exchanger air intake and exhaust ducts (fig. 4-1) by flushing with low-pressure water.

Item No.	Symptom	Probable trouble	Corrective action
1	Xenon lamp does not ignite, blower motor does not operate, CIRCUIT TEST indicator does not light in position 6.	<ul style="list-style-type: none"> a. Cable not connected between search light and control box or bad wire in cable. b. Control switch not in correct position. c. CIRCUIT TEST switch not in operating position. d. Power contactor bad 	<ul style="list-style-type: none"> a. Refer equipment to organizational maintenance. b. Move control switch to correct position. c. Move CIRCUIT TEST switch to operating position. d. Refer equipment to direct support maintenance.
2	Xenon lamp does not ignite, blower motor does not operate, CIRCUIT TEST indicator does not light in position 7. Set power switch to: VISIBLE.	<ul style="list-style-type: none"> a. Control switch not in correct position. b. DC power cable not connected to control box or cable defective. c. Power contractor defective 	<ul style="list-style-type: none"> a. Move control switch to correct position. b. Refer equipment to organizational maintenance. c. Refer equipment to direct support maintenance.
3	Xenon lamp does not ignite, Mower motor operates CIRCUIT TEST indicator lights in position 3 but not in position 4.	<ul style="list-style-type: none"> a. Broken wire between blocking diode and power contactor in control box. b. Blocking diode open in searchlight. 	<ul style="list-style-type: none"> a. Refer equipment to direct support maintenance. b. Refer equipment to direct support maintenance.
4	Xenon lamp does not ignite, blower motor operates, CIRCUIT TEST indicator does not light in position 3.	<ul style="list-style-type: none"> a. B+ to sense board missing b. Broken wire in searchlight. 	<ul style="list-style-type: none"> a. Refer equipment to direct support maintenance. b. Refer equipment to direct support maintenance.
5	Xenon lamp does not ignite, blower motor operates, CIRCUIT TEST indicator does not light in position 2.	<p>Input voltage level below 22 volts</p> <p>Note. MX-8272B/VSS-3 lamp may not ignite if the input voltage level is below 24 volts.</p>	<p>Raise input voltage level to within the range of 22-28 volts.</p>

<i>Item No.</i>	<i>Symptom</i>	<i>Probable trouble</i>	<i>Corrective action</i>
6	Xenon lamp does not ignite, blower motor operates, CIRCUIT TEST indicator lights in all positions.	Defective Xenon lamp	Refer searchlight to organizational maintenance for replacement of Xenon lamp (PARA 5-12).
7	Xenon lamp ignites, blower motor does not operate CIRCUIT TEST indicator does not light in position 5.	a. Broken wire in power cable . . . b. Blower motor relay defective . . .	a. Refer equipment to organizational maintenance. b. Refer equipment to direct support maintenance.
8	Xenon lamp ignites, blower motor does not operate. CIRCUIT TEST indicator lights in position 5.	a. Air intake and exhaust ducts clogged . b. Blower motor defective	c. Clean exhaust ducts (pare 4-6b). b. Refer searchlight to direct support maintenance.
9	Xenon lamp ignites, blower motor operates, beamwidth does not vary. CIRCUIT TEST indicator does not light in position 7.	a. Auxiliary B+ fuse blown (F1) b. Broken wire in cable c. Broken wire in control box . . .	a. Refer equipment to organizational maintenance, b. Refer equipment to organizational maintenance. c. Refer equipment to organizational maintenance.
10	Same as 9 above except CIRCUIT TEST indicator lights in position 7.	a. Defective power cable b. Focus motor defective c. Beam switch defective	a. Refer equipment to organizational maintenance. b. Refer equipment to organizational maintenance. c. Refer equipment to organizational maintenance.
11	Xenon lamp ignites, blower motor operates, searchlight cannot change modes of illumination, CIRCUIT TEST indicator does not light in position 6.	a. Motor fuse blown (F2) b. Power cable to searchlight defective. c. Reverse polarity protection diode CR open.	a. Refer equipment to organizational maintenance. b. Refer equipment to organizational maintenance. c. Refer equipment to organizational maintenance.
12	Same as 11 above except CIRCUIT TEST indicator lights in position 6.	a. Continuity to filter motor broken in searchlight. b. Filter motor bad	a. Refer equipment to organizational maintenance. b. Refer equipment to organizational maintenance.
13	Searchlight does not start from remote control box or remote control box does not control searchlight operation.	a. Control switch in wrong position b. Cable from remote control box to control box defective. c. Defective switch or broken wire in remote control box.	a. Move control switch to correct position. b. Refer equipment to organizational maintenance. c. Refer equipment to organizational maintenance.
14	OVER TEMP indicator lamp comes on during searchlight operation.	a. Air intake and exhaust ducts clogged. b. Continuity to blower motor broken in cable. c. Blower motor defective	a. Clean air intake and exhaust ducts (para 4-6b). b. Refer equipment to organizational maintenance. c. Refer equipment to organizational maintenance.
15	LAMP ON indicator does not light during searchlight operation.	a. Defective indicator lamp b. Broken wire in control box	a. Refer equipment to organizational maintenance. b. Refer equipment to organizational maintenance.
16	Deleted		
17	Searchlight light output dim or beam irregular.	a. Window dirty b. Reflector dirty c. Front window pitted	a. Clean exterior of window (para 4-6) and/or interior of window (para 5-5). b. Refer searchlight to organizational maintenance. c. Refer searchlight to organizational maintenance.

<i>Item No.</i>	<i>Symptom</i>	<i>Probable trouble</i>	<i>Corrective action</i>
18	Searchlight beam too high . .	Searchlight out of vertical adjustment	Refer equipment to direct support maintenance.
19	Searchlight beam defocused .	Reflector-lamp focal length incorrect	Refer searchlight to direct support maintenance.

CHAPTER 5

ORGANIZATIONAL MAINTENANCE

Section I. GENERAL

5-1. Scope of Organizational Maintenance

a. This chapter contains instructions covering organizational maintenance of the searchlight set. It includes instructions for performing preventive and periodic maintenance services and repair functions to be accomplished by the organizational repairman.

b. Organizational maintenance of the searchlight set includes —

- (1) Organizational monthly preventive maintenance checks and services chart (para 5-3).
- (2) Painting and refinishing (para 5-4).
- (3) Organizational cleaning (para 5-5).
- (4) Organizational troubleshooting (paras 5-6 and 5-7),
- (5) Repairs (paras 5-8 through 5-16).

5-2. Tools and Materials Required for Organizational Maintenance

- a. Lamp and holder assembly.
- b. Slotted screwdriver.
- c. Phillip's-type screwdriver.
- d. One-half-inch wrench.
- e. Clean, lint free cloth.
- f. Soap and water.
- g. Alcohol.
- h. Face mask.
- i. Asbestos gloves.
- j. Fine sandpaper.
- k. Paint.
- l. Protective apron.

Section II. ORGANIZATIONAL PREVENTIVE MAINTENANCE

Note : REPLACE XENON TUBE AFTER 300 HOURS OF OPERATION.

5-3. Organizational Monthly Preventive Maintenance Checks and Services

Monthly preventive maintenance checks and services on Searchlight Set, Infrared AN/VSS-3A are

required. All deficiencies must be recorded in accordance with requirements of TM 38-750. Perform all the checks and services in the sequence listed below.

Sequence

<i>No.</i>	<i>Item to be inspected</i>	<i>Procedure</i>	<i>Reference</i>
1	Completeness	Check that equipment is complete	Paras 1-6, 1-8, 1-9, fig. 1-1.
2	Installation	Check that equipment is properly installed	Para 1-6, 1-8, 1-9, fig. 1-1.
3	Cleanliness	Check that equipment is clean	Paras 4-6 and 5-5.
4	Preservation	Check all external and internal surfaces for evidence of fungus, rust, or corrosion. Remove rear cover to check internal surfaces.	Paras 5-4 and 5-17.
5	Publications	Check to see that all publications are complete, serviceable, and current.	DA Pam 310-4.
6	Modifications	Check DA Pam 310-7 to determine if new applicable, MWO's have been published. ALL, URGENT MWO's must be applied immediately All ROUTINE MWO's must be scheduled.	TM 38-750 and DA Pam 310-7.
7	Spare parts	Check operator and organizational spare parts for general condition and method of storage. There should be no overstockage and all shortages must be on valid requisitions.	App. D.
8	Mounting	Check that all exterior bolts are tight	Ch. 2.

Sequence

No.	Item to be inspected	Procedure	Reference
9	Power cable	Inspect for corrosion, stripped threads, damaged insulation, and proper fit to receptacles.	
10	Canvas cover	Inspect for damaged material such as tears and broken tie down straps. Replace cover if worn or damaged.	fig. 1-1. Para 5-17
11	Elapsed Time Meter	Check for advanced reading <i>Note.</i> The Xenon lamp must be replaced every 300 hours.	Para 5-12
12	Searchlight	Perform operational checks <i>Warning 1.</i> Do not operate the searchlight if the blower motor does not operate. <i>Warning 2.</i> Do not look directly into the searchlight beam in either the visual or infrared mode of operation. Serious eye damage may result.	Ch. 3. para 4-5.

5-4. Repainting and Refinishing Instructions

Remove met and corrosion from metal surfaces by sanding them lightly with fine sandpaper. Brush two thin coats of paint on the bare metal to protect it from further corrosion. Refer to applicable cleaning and refinishing practices and materials specified in SB 11-573, TM 9-213, and TB 746-10.

5-5. Organizational Cleaning

Refer to paragraph 4-6 for procedures for cleaning exterior surfaces, heat exchanger and the searchlight window exterior. In addition, organizational maintenance is responsible for cleaning the reflector and the interior of the searchlight window.

WARNING

1. Make sure that the searchlight has been turned off for at least 15 minues before performing the following procedures.
2. When working around the reflector assembly, make certain that protective clothing, face mask, and gloves are worn. The Xenon lamp is filled with Xenon gas under high pressure, and may explode if jarred.

- a. Remove the case window (para 5-11).
- b. Clean inside surface of case window using soap and water. Rinse away soap and dry case window with a clean, lint free cloth.

CAUTION

1. The reflector is delicate and easily scratched. Searchlight performance will be impaired if reflector surface is scratched. Use extreme caution in cleaning the reflector. Do not use any cleaning solvents or abrasive compounds.
2. Do not leave water on interior of searchlight. Possible shorting of components and serious damage to the searchlight could occur.

- c. Clean the reflector assembly using soap and water on a dampened cloth. Gently wipe from center to outer edge. To remove soap film, use a clean damp cloth. Do not use any cleaning solvents or abrasive compounds on the reflector.
- d. Install the case window (para 5-11).

Section III. ORGANIZATIONAL TROUBLESHOOTING AND REPAIRS

5-6. General

Troubleshooting of this equipment is based on the operational checks described in paragraph 4-5, sequence Nos. 9 through 14. To troubleshoot the equipment; follow the operational checks until a trouble symptom is found, and then refer to the troubleshooting chart (para 5-7). Locate the trouble symptom in the chart, isolate the trouble using the CIRCUIT TEST switch and indicator, and perform the indicated corrective action. If the trouble symptom is not listed, refer to higher category of maintenance. After performing each corrective

action sequence, return to the starting procedure to check whether the trouble symptom is still present. If the symptom is still present, refer to higher category of maintenance.

WARNING

Do not operate searchlight while personnel are within 320 meters of the beam path; eye damage will result.

NOTE

Check to be sure that the CIRCUIT TEST indicator lamp is not defective before starting the troubleshooting procedure.

5-7. Organizational Troubleshooting Chart

<i>Item No.</i>	<i>Symptom</i>	<i>Probable trouble</i>	<i>Corrective action</i>
1	Xenon lamp does not ignite, blower motor does not operate, CIRCUIT TEST indicator does not light in position 6.	<ul style="list-style-type: none"> a. Cable not connected between searchlight and control box or bad wire in cable. b. Control switch not in correct position. c. CIRCUIT TEST switch not in operating position d. Power contactor bad 	<ul style="list-style-type: none"> a. Connect or replace cable (para 5-10). b. Move control switch to correct position. c. Move CIRCUIT TEST switch to operating position. d. Refer equipment to direct support maintenance.
2	Xenon lamp does not ignite, blower motor does not operate, CIRCUIT TEST indicator does not light in position 7. Set power switch to VISIBLE.	<ul style="list-style-type: none"> a. Control switch not in correct position. b. DC power cable not connected to control box or cable defective. c. Power contactor defective. 	<ul style="list-style-type: none"> a. Move control switch to correct position. b. Connect DC power cable or replace defective cable (para 5-10). c. Replace control box (para 5-15).
3	Xenon lamp does not ignite, blower motor operates, CIRCUIT TEST indicator lights in position 3 but not in position 4.	<ul style="list-style-type: none"> a. Broken wire between blocking diode and power contactor. b. Blocking diode open in searchlight 	<ul style="list-style-type: none"> a. Refer equipment to direct support maintenance. b. Refer equipment to direct support maintenance.
4	Xenon lamp does not ignite, blower motor operates, CIRCUIT TEST indicator does not light in position 3.	<ul style="list-style-type: none"> a. B+ to sense board missing b. Broken wire in searchlight. 	<ul style="list-style-type: none"> a. Refer equipment to direct support maintenance. b. Refer equipment to direct support maintenance.
5	Xenon lamp does not ignite, blower motor operates, CIRCUIT TEST indicator does not light in position 2.	Input voltage level below 22 volts <i>Note.</i> MX-8272B/VSS-3 may not ignite if the input voltage level is below 24 volts.	Raise input voltage level above 22 volts.
6	Xenon lamp does not ignite, blower motor operates, CIRCUIT TEST indicator lights in all positions.	Defective Xenon lamp	Replace Xenon lamp (para 5- 12). <i>Note.</i> If after replacing the xenon lamp the lamp still will not ignite, reinstall the original lamp in the searchlight and refer to higher category of maintenance.
7	Xenon lamp ignites, blower motor does not operate CIRCUIT TEST indicator does not light in position 5.	<ul style="list-style-type: none"> a. Broken wire in power cable b. Blower motor relay defective 	<ul style="list-style-type: none"> a. Replace power cable (para 5-10), b. Replace control box (para 5-15).
8	Xenon lamp ignites, blower motor does not operate, CIRCUIT TEST indicator lights in position 5.	<ul style="list-style-type: none"> a. Air intake and exhaust ducts clogged . . . b. Blower motor defective. 	<ul style="list-style-type: none"> a. Clean exhaust ducts (para 4-6b). b. Refer searchlight to direct support maintenance.
9	Xenon lamp ignites, blower motor operates, beamwidth does not vary, CIRCUIT TEST indicator does not light in position 7.	<ul style="list-style-type: none"> a. Auxiliary B+ fuse blown (F1) b. Broken wire in cable c. Broken wire in control box. 	<ul style="list-style-type: none"> a. Replace auxiliary B+ fuse (para 5-8). b. Replace power cable (para 5-10). c. Replace control box (para 5-15).
10	Same as 9 except CIRCUIT TEST indicator lights in position 7.	<ul style="list-style-type: none"> a. Defective power cable b. Focus motor defective c. Beam switch defective 	<ul style="list-style-type: none"> a. Replace power cable (para 5-10). b. Replace searchlight (para 5-13). c. Replace control box (para 5-15).
11	Xenon lamp ignites, blower motor operates, searchlight cannot change modes of illumination, CIRCUIT TEST indicator does not light in position 6.	<ul style="list-style-type: none"> a. Motor fuse blown (F2) 	<ul style="list-style-type: none"> a. Replace motor fuse (para 5-8).
12	Same as 11 except CIRCUIT TEST indicator lights in position 6.	<ul style="list-style-type: none"> a. Continuity to filter motor broken in searchlight. b. Filter motor bad... 	<ul style="list-style-type: none"> a. Replace searchlight (para 5-15). b. Replace searchlight (para 5-13).
13	Searchlight does not start from remote control box or remote control box does not control searchlight operation.	<ul style="list-style-type: none"> a. Control switch in wrong position. b. Cable from remote control box to control box defective. c. Defective stitch or broken wire in remote control box. 	<ul style="list-style-type: none"> a. Move control switch to correct position. b. Replace defective cable (para 5-10). c. Replace remote control box (para 5-16).
14	OVER TEMP indicator lamp comes on during searchlight operation.	<ul style="list-style-type: none"> a. Air intake and exhaust ducts clogged. . . b. Continuity or blower motor broken in cable. c. Blower motor defective, 	<ul style="list-style-type: none"> a. Clean air intake and exhaust ducts (para 4-6b). b. Replace power cable (para 5-10). c. Replace searchlight.

Item

No.	Symptom	Probable trouble	Correction action
15	LAMP ON indicator does not light during searchlight operation.	a. Defective indicator lamp	a. Replace defective lamp (para 5 13).
		b. Broken wire in control box	b. Replace control box (para 5-9).
16	ELAPSED TIME indicator does not advance during searchlight operation.	Defective meter	Refer equipment to direct support maintenance.
17	Searchlight light output dim or beam irregular.	a. Window dirty	a. Clean exterior of window (para 4-6) and/or interior window (para 5-5).
		b. Reflector dirty	b. Clean reflector (para 5-5c).
		c. Front window pitted	c. Replace front windows (para 5-11).
18	Searchlight beam too high	Searchlight out of vertical adjustment	Refer equipment to direct support maintenance.
19	Searchlight beam defocused	Reflector-lamp focal length incorrect.	Refer searchlight to direct support maintenance.

5-8. Replacement of Fuses
(fig. 3-1,3-1.1, and 5-1)

CAUTION

Always replace a blown fuse with one of the same rating and type. If replacement

fuse blows, do not install another fuse until the trouble has been remedied. The following table lists the rating, indication of blow fuse, and location of fuses within the equipment:

a. Control Box C-7905A.

Fuse	Rating vo/ts	Amps	Blown fuse indication	Location
F1	250	2	Search beamwidth will not vary.	Front of control box.
F2	250	1	Searchlight will not switch illumination modes.	Front of control box.

b. Control Box C-7905B.

Fuse	Rating volts	Amps	Blown fuse indication	Location
F1	250	2	Search beamwidth will not vary.	Front of control box.
F2	250	1/2 slo-blow	Searchlight will not switch illumination modes.	Front of control box.

- To remove and replace, proceed as follows:
- Unscrew the fuse cap counterclockwise and pull the cap and fuse out of the fuse holder.
 - Replace the fuse (2) or (3) in the cap.
 - Insert fuse and cap into the fuse holder.
 - Turn the cap clockwise until tight.

5-9. Replacement of Indicator Lamps
(fig. 5-1)

The procedure for replacement of defective indicator lamps in the control box and remote control box is as follows.

- Locate defective indicator and remove by turning indicator lens assembly counterclockwise.
- Remove defective indicator lamp from indicator lens assembly.
- Insert a new indicator lamp into the indicator lens assembly.
- Insert lens in control box or remote control box and tighten in a clockwise direction.

5-10. Replacement of Searchlight Set Cables.

WARNING

Dangerous voltages are present around the searchlight set cables. The searchlight must be turned off and the input power cable at J 1 on the control box disconnected before replacing any cables.

No specific instructions are required to replace the searchlight set cables. Make sure that connectors are properly aligned and tight when installing the new cable.

5-11. Replacement of Front Window
(fig. 5-2)

CAUTION

Window assembly must be carefully removed from searchlight to prevent glass breakage.

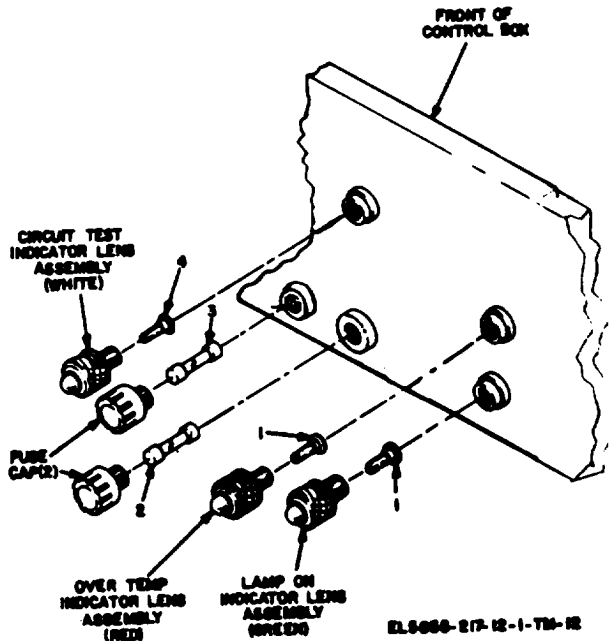

- 1 28-volt lamp
- 2 Motor fuse
- 3 Auxiliary B+ fuse
- 4 18-volt lamp

Figure 5-1. Replacement of indicator lamps and fuses.

a. To remove window, perform the following steps:

(1) Remove safety bale from window clamp handle.

(2) Unlatch window clamp.

(3) Loosen window coupling (1) and remove front window assembly from flange on front of searchlight.

(4) Remove window (2) and gasket (3) from window coupling (1).

(5) Remove gasket from around window. If window is broken, remove all broken pieces from gasket.

b. To install window, perform the following steps:

(1) Attach the gasket (3) around the new window.

(2) Position the window coupling (1) around the gasket (3).

(3) Position the flange on the front of the searchlight inside the lip of the window coupling as shown in detail on figure 5-2.

(4) Insure that the window gasket is properly seated around the flange.

(5) Latch the window clamp.

(6) Secure clamp handle with safety bale.

5-12. Replacement of Xenon Lamp

(fig. 5-2)

WARNING

1. The Xenon lamp is under high internal

pressure and must be handled with care. If dropped or given a sharp blow, it can explode violently.

2. The glass envelope of the lamp must never be touched with bare hands, dirty gloves, or rags. Finger acids and dirt can cause spots on the envelope which, in turn, can cause violent failure of the lamp.

3. The spare lamp is contained inside a lampholder and held in place by tape covering the open end of holder. The holder is also used as a tool for removing and installing the lamp. To insure personal safety during lamp replacement, lamp must always remain inside the holder until lamp installation has been completed.

4. Wear a face mask, asbestos gloves, and a protective apron when removing and replacing the Xenon lamps.

5. The window should not be removed or the Xenon lamp worked on until the searchlight has been off for at least 15 minutes.

To replace the Xenon lamp, perform the following steps:

a. Disconnect the power cable at searchlight to prevent accidental shock.

b. Release safety bail on handle of clamp. Loosen window coupling (1) and remove front window assembly from flange on front of searchlight.

NOTE

Leave window gasket around perimeter of window.

c. Remove screw (4), lockwasher (5), and flat washer (6) holding wire terminal to front of lamp clip (8) and remove wire terminal and spacer (7).

d. Remove and retain four screws (9), lockwashers (10), and flat washers (11), holding lamp clip (8) to front of lamp support assembly.

e. Carefully pull lamp clip (8) and gasket (12) away from lamp support assembly.

f. Insert an empty lampholder (13) through opening in lamp support assembly and slide it inward until end of travel is felt.

g. Unscrew Xenon lamp (14) in a counterclockwise direction, using lampholder as a tool.

h. Remove lamp and holder assembly (13 and 14) from lamp support assembly. Tape open end of lampholder to prevent lamp from slipping out of container.

NOTE

Do not discard lamp and holder assembly until procedures listed below have been completed.

i. Install replacement lamp and holder (13 and 14) through opening in lamp support assembly.

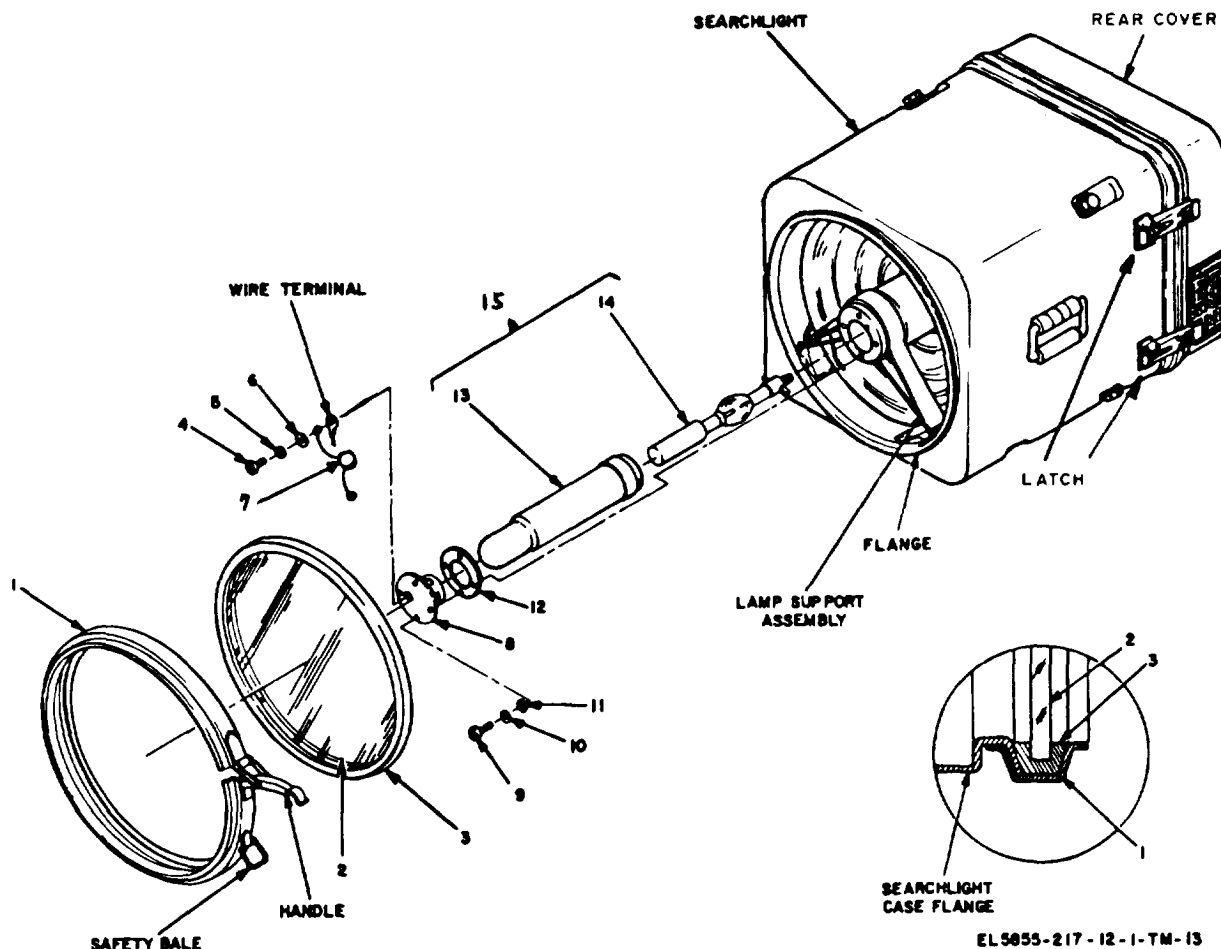

- | | | | |
|---------------------------|--------------|---------------|------------------------|
| 1 Coupling, clamp grooved | 5 Lockwasher | 9 screw | 13 Lampholder |
| 2 Front window glass | 6 Flatwasher | 10 Lockwasher | 14 Xenon lamp |
| 3 Gasket | 7 Capacitor | 11 Flatwasher | 15 Lampholder assembly |
| 4 Screw | 8 Lamp Clip | 12 Gasket | |

Figure 5-2. Replacement of front window and Xenon lamp.

j. Carefully turn lampholder clockwise until Xenon lamp has been securely fastened into place.

k. Remove lampholder from lamp support assembly. Save lampholder for use as a tool for future lamp replacement. Insert lamp clip (8) into place by aligning the four clip mounting holes with the four threaded holes located on the face of the lamp support assembly.

1. Install the four screws (9) and washers (10 and 11) to secure lamp clip (8) and gasket (12) to lamp support assembly. Make certain that all four screws are tight.

m. Insert spacer (7) into lamp clip (8) and secure wire terminal to lamp clip with a screw (4), lockwasher (5), and flat washer (6).

n. Carefully install window clamp and safety bail.

o. Connect power cable to searchlight receptacle.

p. Turn searchlight on and check for lamp ignition.

(1) Lamp ignites, see note below.

(2) Lamp does not ignite, see Organizational Troubleshooting Chart (para 5-7 item 6).

NOTE

Bury or discard lamp in such a manner as to avoid personnel coming in contact with Xenon lamp inside lampholder.

5-13. Replacement of Searchlight

WARNING

Dangerous voltages are present around the searchlight assembly. Turn the searchlight set off and disconnect the input power cable from the control box before replacement procedure is started.

a. To remove searchlight from the vehicle, perform the following steps.

(1) Disconnect power cable from receptacle on searchlight.

(2) Disconnect and remove the three mounting pins holding the searchlight support to vehicle support while searchlight is held by carrying handles by two men.

(3) Lift searchlight off vehicle support and remove

from vehicle.

b. To replace searchlight on vehicle, perform the following steps:

(1) Lift searchlight onto vehicle support and align support with searchlight mount.

(2) Install the three quick-release pins to connect searchlight support to vehicle support.

(3) Connect power cable to receptacle on searchlight.

5-14. Replacement of Support

a. To remove the searchlight support from searchlight, perform the following steps:

(1) Remove searchlight from vehicle (para 5-13).

(2) Set searchlight on left side.

(3) Using a suitable wrench, remove the four bolts and washers attaching the support to the searchlight.

b. To replace the searchlight support on the searchlight, perform the following steps:

(1) Position searchlight support on the searchlight.

(2) Install mounting bolts and washers onto searchlight support and tighten with a wrench.

5-15. Replacement of Control Box

a. To remove the control box from the vehicle perform the following steps:

(1) Disconnect all cables attached to the control box.

(2) Remove the four screws securing the control box mounting plate to the vehicle.

(3) Remove the control box from the vehicle.

b. To replace the control box in the vehicle, perform the following steps:

(1) Position control box so that the four holes in the mounting plate are aligned with the four mounting holes in the vehicle.

(2) Install and tighten four mounting screws securing control box to the vehicle.

(3) Attach connecting cables to their respective receptacles on the control box.

5-16. Replacement of Remote Control Box

a. To remove the remote control box from the tank, perform the following steps:

(1) Disconnect cable to remote control box.

(2) Remove the four mounting screws and washers holding the remote control box to the vehicle.

(3) Remove the remote control box from the vehicle.

b. To replace remote control box in vehicle, perform the following steps:

(1) Position remote control box to align the four mounting holes in the mounting plate with the four mounting holes in the vehicle.

(2) Install and tighten four mounting screws through mounting plate into vehicle.

(3) Attach remote control box interconnecting cable to receptacle on remote control box.

5-17. Reading ELAPSED TIME Meter

a. On some models, the ELAPSED TIME meter is visible from the front of the searchlight.

(1) The ELAPSED TIME meter is mounted on the upper left of the main support assembly.

(2) Using a flashlight, look into the front of the searchlight lens to your left above and behind the reflector.

(3) Read and record the elapsed time.

b. If the ELAPSED TIME meter is located in the rear, remove the rear cover to read the time (fig. 5-2).

(1) Release the four latches that hold the rear cover to the searchlight.

(2) Remove the rear cover. Be careful not to damage the wires from the searchlight to the rear cover.

(3) The ELAPSED TIME meter is mounted on the main support assembly,

(4) After checking and recording the meter reading, replace and relatch the rear cover of the searchlight.

NOTE

The elapsed time meter records in hours.

CHAPTER 6

SHIPMENT, LIMITED STORAGE, AND DEMOLITION TO PREVENT ENEMY USE

Section I. DISASSEMBLY AND REPACKAGING OF EQUIPMENT

6-1. Disassembly of Searchlight Set

- a. Remove the searchlight (para 5-13a).
- b. Remove the control box (para 5-15a).
- c. Remove the remote control box (para 5-16a).
- d. Remove the power cable (para 5-10).

6-2. Repackaging

Package the searchlight set as shown in figure 2-1.

6-3. Limited Storage

When the searchlight set is stored for a limited time, perform the following procedures:

- a. Inventory all components to verify that the searchlight set is complete and serviceable (fig. 1-1). Unserviceable spare parts or components should be repaired or replaced.
- b. Thoroughly clean the equipment (para 4-6 and 6-6).
- c. Remove all traces of rust and corrosion and repaint surfaces that have been damaged (para 5-4).
- d. Place the canvas cover on the searchlight.

Section II. DEMOLITION TO PREVENT ENEMY USE

6-4. Authority of Demolition

The demolition procedures given in paragraph 6-6 will be used to prevent the enemy from using or salvaging this equipment. Demolition of the equipment will be accomplished only upon the order of the commander,

6-5. Destruction Plan

Field manuals direct that a destruction plan for equipment will be prepared. Personnel should be assigned specific tasks so that minimum time will be required if destruction is necessary. Personnel should be familiar with all aspects of the overall destruction plan. The plan must be complete, adequate, capable of being easily carried out in the field, and provide for destruction as complete as the available time, equipment, and personnel will permit. Because of the time required, complete destruction may not always be available. Field manuals also direct that destruction priorities be established to insure that essential parts of equipments will be destroyed first. Priority in the following order is suggested for the searchlight set:

- a. The highest priority for destruction should be given to the major components which are most

essential for searchlight operation; the Xenon lamp, reflector, infrared filter assembly, control box, and remote control box.

- b. Next to be destroyed are the minor components; the searchlight window, rear cover assembly (heat exchanger), searchlight housing, and power cable.

- c. The technical manual is to be destroyed after the minor components are destroyed.

- d. The spare parts and the searchlight cover are the last items in the order of destruction.

6-6. Methods of Destruction

Any or all of the methods of destruction given below may be used. In most instances the available time will be the single determining factor as to the method to be used for destroying equipment. The tactical situation will also determine how the destruction order will be carried out. However, in most cases it is preferable to completely demolish some portions of the equipment rather than to partially destroy all the equipment. The destruction methods described in *a*, *b*, and *c* below are given in order of preference, Burning is the preferred method.

a. Burning. Burn as much of the searchlight set as is flammable by using gasoline, kerosene, flame-throwers, etc. Remove the window and heat exchanger, pour gasoline on all components inside the searchlight housing and inside the control box, and on the technical manual, remote control box power cable, spare parts, and searchlight cover, and ignite,

WARNING

Be extremely careful in the use of explosives and small arms fire. These items should not be used unless extreme urgency demands their use.

b. Explosives. Powder charges, fragmentation grenades, or incendiary grenades may be used in any of the applications given below.

(1) Remove the window or heat exchanger and place a charge or grenade inside the searchlight housing.

(2) Pile the remote control box, control box power cable, technical manual, spare parts, and canvas cover and attach a charge or grenade in the middle of the pile.

WARNING

Use caution and clear the surrounding area when using small arms fire. Glass and metal fragments may spray out in any direction,

c. Small Arms Fire.

(1) From a safe distance, direct the available firepower toward the window of the searchlight. Be sure to destroy the Xenon lamp, infrared filter assembly, and reflector.

(2) Direct firepower toward the heat exchanger.

(3) Destroy the remote control box, control box, and power cable.

(4) Destroy the technical manual, spare parts, and canvas cover.

6-7. Methods of Disposal

Bury or scatter destroyed parts and miscellaneous parts or throw them into nearby waterways. This is particularly important if a number of parts have not been completely destroyed.

APPENDIX A

REFERENCES

The following is a list of the applicable references available to the operator and organizational maintenance personnel of Searchlight Set, Infrared AN/VSS-3A.

DA Pam 310-4	Index of Technical Manuals, Technical Bulletins, Supply Manuals (Types 7, 8, and 9), Supply Bulletins, and Lubrication Orders.
DA Pam 310-7	US Army Equipment Index of Modification Work Orders
SB 11-573	Painting and Preservation Supplies Available for Field Use for Electronic Command Equipment
SB 38-100	Preservation, Packaging, and Packing Materials, Supplies, and Equipment Used by the Army
TB 43-0118	Field Instructions for Painting and Preserving Electronics Command Equipment Including Camouflage Pattern Painting of Electrical Equipment Shelters.
M 11-5855-217-12-2	Operator's and organizational Maintenance Manual Searchlight Set, Infrared AN/VSS-3 (NSN 5855-00-058-1293) and Searchlight Set, Infrared AN/VSS-3A (NSN 5855-00-177-3529; NSN 5855-00-405-0404) .
TM 38-750	The Army Maintenance Management System (TAMMS).

APPENDIX B

BASIC ISSUE ITEMS LIST AND
ITEMS TROOP INSTALLED OR AUTHORIZED LIST

SECTION I. INTRODUCTION

B-1. Scope

This appendix lists basic issue items, items troop installed or authorized and required by the crew/operator for operation of the AN/VSS-3A, Federal Stock Numbers 5855-177-3529 and 5855-405-0404.

B-2. General

This Basic Issue Items, Items Troop Installed or Authorized is divided into the following sections:

a. Basic Issue Items List – Section II. A list, in alphabetical sequence, of items which are furnished with, and which must be turned in with, the end item.

b. Items Troop Installed or Authorized List – Section III. A list, in alphabetical sequence, of items which, at the discretion of the unit commander, may accompany the end item, but are not subject to be turned in with the end item.

B-3. Explanation of Columns in the Basic Issue Items List – Section II

a. Illustration, Column 1. This column is divided as follows:

(1) Figure Number, Column 1a. This column indicates the figure number of the illustration in which the item is shown.

(2) Item Number, Column 1 b. This column indicates the callout number used to reference the item in the illustration.

b. Federal Stock Number, Column 2. This column indicates the Federal stock number assigned to the item and will be used for requisitioning purposes.

c. Description, Column 3. This column indicates the Federal item name and any additional description of the item required. A part number or other reference number is followed by the applicable five-digit Federal Supply Code for Manufacturer (FSCM) in parentheses. The FSCM is used as an element in item identification to designate manufacturer, distributor, or Government Agency, etc., and is identified in SB 708-42. Identifications of the useable on codes used are:

Code	Used On
A	FSN 5855-177-3529
B	FSN 5855-405-0404

d. Quantity Furnished With Equipment, Column 4. This column indicates the quantity of an item furnished with the equipment.

B-4. Explanation of Columns in the Items Troop Installed or Authorized List – Section III.

a. Federal Stock Number, Column 1. Indicates the Federal stock number assigned to the item and will be used for requisitioning purposes.

b. Description, Column 2. Indicates the Federal item name and a minimum description required to identify the item. The last line indicates the reference number followed by the applicable Federal Supply Code for Manufacturer (FSCM) in parentheses. The FSCM is used as an element in item identification to designate manufacturer, distributor, or Government Agency, etc., and is identified in SB 708-42. Identifications of the useable on codes used are:

Code	Used On
A	FSN 5855-177-3529
B	FSN 5855-405-0404

c. Unit of Measure (U/M), Column 3.
Indicates the standard or basic quantity by which the listed item is used in performing the actual maintenance function. This measure is expressed by a two-character alphabetical abbreviation, e.g., ea, in, pr, etc.

d. Quantity Authorized, Column 4.
Indicates the quantity of the item authorized to be used with the equipment.

SECTION II BASIC ISSUE ITEMS

(1) ILLUSTRATION		(2) FEDERAL STOCK NUMBER	(3) DESCRIPTION	USA&&ON	(4) QUANTITY W/IT EQU.
(a) FIG NO	(b) ITEM NO		PART NUMBER & FSCM		
I-1	1	5975-123-1527	COVER ASSEMBLY, SEARCHLIGHT SCD647202 1 (80063)	A. B	1

SECTION III **ITEMS TROOP INSTALLED OR AUTHORIZED LIST**

FEDERAL STOCK NUMBER	(2) DESCRIPTION ARTI NUMBER & FSCM	(3) U/M	(4) QT Δ1/1
62501341757	EXTRACTOR ASSEMBLY RSI SCD646813 (80063)	A. 8	-

APPENDIX C

MAINTENANCE ALLOCATION

Section 1. INTRODUCTION

C-1. General

This appendix provides a summary of the maintenance operations for AN/VSS-3A. It authorizes categories of maintenance for specific maintenance functions on repairable items and components and the tools and equipment required to perform each function. This appendix may be used as an aid in planning maintenance operations.

C-2. Maintenance Function

Maintenance functions will be limited to and defined as follows:

a. Inspect. To determine the serviceability of an item by comparing its physical, mechanical, and/or electrical characteristics with established standards through examination.

b. Test. To verify serviceability and to detect incipient failure by measuring the mechanical or electrical characteristics of an item and comparing those characteristics with prescribed standards.

c. Service. Operations required periodically to keep an item in proper operating condition, i.e., to clean (decontaminate), to preserve, to drain, to paint, or to replenish fuel, lubricants, hydraulic fluids, or compressed air supplies.

d. Adjust. To maintain, within prescribed limits, by bringing into proper or exact position, or by setting the operating characteristics to the specified parameters,

e. Align. To adjust specified variable elements of an item to bring about optimum or desired performance.

f. Calibrate. To determine and cause corrections to be made or to be adjusted on instruments or test measuring and diagnostic equipments used in precision measurement. Consists of comparisons of two instruments, one of which is a certified standard of known accuracy, to detect and adjust any discrepancy in the accuracy of the instrument being compared.

g. Install. The act of emplacing, seating, or fixing into position an item, part, module (component or assembly) in a manner to allow the proper functioning of the equipment or system.

h. Replace. The act of substituting a serviceable like type part, subassembly, or module (component or assembly) for an unserviceable counterpart.

e. Repair. The application of maintenance services (inspect, test, service, adjust, align, calibrate, replace) or other maintenance actions (welding,

grinding, riveting, straightening, facing, re-machining, or resurfacing) to restore serviceability to an item by correcting specific damage, fault, malfunction, or failure in a part, subassembly, module (component or assembly), end item, or system. This function does not include the trial and error replacement of running spare type items such as fuses, lamps, or electron tubes.

j. Overhaul. That maintenance effort (service/action) necessary to restore an item to a completely serviceable/operational condition as prescribed by maintenance standards (i.e., DMWR) in appropriate technical publications. Overhaul is normally the highest degree of maintenance performed by the Army, Overhaul does not normally return an item to like new condition.

k. Rebuild. Consists of those services/actions necessary for the restoration of unserviceable equipment to a like new condition in accordance with original manufacturing standards. Rebuild is the highest degree of materiel maintenance applied to Army equipment. The rebuild operation includes the act of returning to zero those age measurements (hours, miles, etc.) considered in classifying Army equipments/components.

C-3. Column Entries

a. Column 1, Group Number. Column 1 lists group numbers, the purpose of which is to identify components, assemblies, subassemblies, and modules with the next higher assembly.

b. Column 2, Component/Assembly. Column 2 contains the noun names of components, assemblies, subassemblies, and modules for which maintenance is authorized.

c. Column 3, Maintenance Functions. Column 3 lists the functions to be performed on the item listed in column 2. When items are listed without maintenance functions, it is solely for purpose of having the group numbers in the MAC and RPSTL coincide.

d. Column 4, Maintenance Category. Column 4 specifies, by the listing of a "work time" figure in the appropriate subcolumn(s), the lowest level of maintenance authorized to perform the function listed in column 3. This figure represents the active time required to perform that maintenance function at the indicated category of maintenance. If the number or complexity of the tasks within the listed maintenance function vary at different

maintenance categories, appropriate "work time" figures will be shown for each category. The number of task-hours specified by the "work time" figure represents the average time required to restore an item (assembly, subassembly, component, module, end item or system) to a serviceable condition under typical field operating conditions. This time includes preparation time, troubleshooting time, and quality assurance/quality control time in addition to the time required to perform the specific tasks identified for the maintenance functions authorized in the maintenance allocation chart. Subcolumns of column 4 are as follows:

- C — Operator/Crew
- O — Organizational
- F — Direct Support
- H — General Support
- D — Depot

e. Column 5, Tools and Equipment. Column 5 specifies by code, those common tool sets (not individual tools) and special tools, test, and support equipment required to perform the designated function.

f. Column 6, Remarks. Column 6 contains an alphabetic code which leads to the remark in section IV, Remarks, which is pertinent to the item opposite the particular code.

C-4. Tool and Test Equipment Requirements (Sect. III)

a. Tool or Test Equipment Reference Code. The numbers in this column coincide with the numbers used in the tools and equipment column of the MAC. The numbers indicate the applicable tool or test equipment for the maintenance functions.

b. Maintenance Category. The codes in this column indicate the maintenance category allocated the tool or test equipment.

c. Nomenclature. This column lists the noun name and nomenclature of the tools and test equipment required to perform the maintenance functions.

d. National/NATO Stock Number. This column lists the National/NATO stock number of the specific tool or test equipment.

e. Tool Number. This column lists the manufacturer's part number of the tool followed by the Federal Supply Code for manufacturers (5-digit) in parentheses.

C-5. Remarks (Sect. IV)

a. Reference Code. This code refers to the appropriate item in section II, column 6.

b. Remarks. This column provides the required explanatory information necessary to clarify items appearing in section II.

(Next printed page is C-3)

SECTION II MAINTENANCE ALLOCATION CHART
FOR

SEARCHLIGHT SET, INFRARED AN/VSS-3A

(1) GROUP NUMBER	(2) COMPONENT/ASSEMBLY	(3) MAINTENANCE FUNCTION	(4) MAINTENANCE CATEGORY					(5) TOOLS AND EQPT.	(6) REMARKS
			C	O	F	H	D		
00	SEARCHLIGHT SET, INFRARED AN/VSS-3A	Inspect Inspect Test Service Service Adjust Adjust Install Replace Replace Repair Overhaul	0.2 0.3 0.5	0.5 1.0 1.0 1.0 0.5 0.5	1.0 1.0 0.5 10.0		1.0 40.0	2, 6, 8 1 1 3, 4, 6, 8 3, 4, 6, 8 1 1, 2, 3, 4, 5, 6 1, 2, 3, 4, 5, 6 2, 3, 4, 5, 6, 8 2, 3, 4, 5, 7, 8	
01	REMOTE CONTROL BOX C-7906A/VSS-3 AND C-7906B/VSS-3	Replace Repair		0.3	1.5			1 2, 3, 4, 5	
02	CONTROL BOX C-7905A/VSS-3 AND C-7905B/VSS-3	Repair Repair		0.3	2.0			1 2, 3, 4, 5, 6	
0201	FRONT PANEL ASSEMBLY	Repair			2.0			2, 3, 4, 5, 6	
020101	MOUNTING BRACKET ASSEMBLY CIRCUIT CARD, TIMER ASSEMBLY	Repair Replace			0.8 0.5			2, 3, 4, 5, 6 2, 3, 4, 5, 6	A
03	SEARCHLIGHT IR MX-8272A/VSS-3 AND MX-8272B/VSS-3	Test Adjust Adjust Replace Repair			1.0 1.0 1.0 10.0		3.0	2, 3, 4, 5, 6, 8 3, 4, 6, 7, 8 3, 4, 6, 7, 8 1 2, 3, 4, 5, 6, 8	
0301	REAR COVER ASSEMBLY	Repair			2.0			2, 4, 5, 6	
030101	CENTRIFUGAL FAN ASSEMBLY	Repair			2.0			2, 4, 5, 6	
0302	SEARCHLIGHT SUPPORT ASSEMBLY	Replace Repair		0.5	2.0			1 2, 4, 5, 6	
	XENON LAMP SENSE CIRCUIT CARD CONVERTER CIRCUIT CARD	Replace Replace Replace		0.5	1.0 1.0			1	A A A
030201	COMPONENT MOUNTING BRACKET ASSEMBLY	Repair			10.0			2, 4, 5, 6	
030202	LEFT BRACKET ASSEMBLY	Repair			0.5			2, 4, 5, 6	
030203	RIGHT BRACKET ASSEMBLY	Repair			0.5			2, 4, 5, 6	
030204	FOCUS CONTROL ASSEMBLY	Repair			1.0			2, 4, 5, 6	
04	ADAPTER KIT M-60	Replace		0.5				1	
0401	SEARCHLIGHT MOUNT ASSEMBLY	Repair			1.0			4, 5	
05	ADAPTER KIT M-551	Replace		0.5				1	

SECTION III. **TOOL** AND TEST EQUIPMENT REQUIREMENTS
 FOR
SEARCHLIGHT SET, INFRARED AN/VSS-3A

TOOL OR TEST EQUIPMENT REF CODE	MAINTENANCE CATEGORY	NOMENCLATURE	NATIONAL/NATO STOCK NUMBER	TOOL NUMBER
1	0	TOOL KIT, ELECTRONIC EQUIPMENT TK-101/G	5180-00-064-5176	
2	F,H,D	MULTIMETER AN/USM-223 (IF NOT AVAILABLE, USE MULTIMETER TS-352B/U)	6625-00-999-7465	
3	F,H,D	OSCILLOSCOPE AN/USM-281A	6625-00-228-2201	
4	F,H,D	TOOL KIT, ELECTRONIC EQUIPMENT TK-100/G	5180-00-605-0079	
5	F,H,D	TOOL KIT, ELECTRONIC EQUIPMENT TK-105/G	5180-00-610-8177	
6	F,H,D	POWER SUPPLY PP-1656/G	6130-00-985-8130	
7	D	POWER SUPPLY PP-4606/G	6130-00-504-0327	
8	F,H,D	ADAPTER, CONNECTOR	5935-00-004-8848	

SECTION IV. REMARKS

REFERENCE CODE	REMARKS
A	Items which are not repaired but are listed for information only.

APPENDIX D
ORGANIZATIONAL MAINTENANCE REPAIR PARTS AND
SPECIAL TOOLS LIST

Section I. INTRODUCTION

D-1. Scope

This appendix lists repair parts, special tools, and test equipment required for the performance of organizational maintenance of the AN/VSS-3A. Federal Stock Number 5855-177-3529

D-2. General

This repair parts and special tools list is divided into the following sections:

a. Repair Parts List—Section II. A list of repair parts authorized at the organizational level for the performance of maintenance. The list also includes parts which must be removed for replacement of the authorized parts. Parts lists are composed of functional groups in ascending numerical sequence.

b. Special Tools List—Section III. Not Applicable.

c. Federal Stock Number and Reference Number Index—Section IV. A list, in ascending numerical sequence, of all Federal stock numbers appearing in the listings, followed by a list, in alphanumeric sequence, of all reference numbers appearing in the listings. Federal stock numbers and reference numbers are cross referenced to each illustration figure number and item number appearance.

D-3. Explanation of Columns

The following provides an explanation of columns in the tabular lists of sections II, III and IV.

a. Source, Maintenance, and Recoverability Codes (SMR), Column 1.

(1) *Source Code.* Indicates the manner of acquiring support items for maintenance, repair or overhaul of end items. Source Codes are:

<i>Code</i>	<i>Explanation</i>
PA	Item procured and stocked for an anticipated or known usage.
PD	Support item, excluding support equipment, procured for initial issue or outfitting and stocked only for subsequent or additional initial issues or outfittings. Not subject to automatic replenishment.

Note 1. Cannibalization or salvage may be used as a source of supply for any items source coded above except, those coded XA and aircraft support items as restricted by AR 700-42.

(2) *Maintenance Code.* Maintenance codes are assigned to indicate the levels of maintenance authorized to USE and REPAIR support items. The maintenance codes are entered in the third and fourth positions of the Uniform SMR Code Format as follows:

USE (THIRD POSITION): The maintenance code entered in the third position will indicate the lowest maintenance level authorized to remove, replace, and use the support item for removal and replacement at the indicated maintenance level will require that all the capabilities necessary to install and insure proper operation after installation of a replacement item (i.e., preinstallation inspection, testing and post-installation checkout) are provided. The maintenance code entered in the third position will indicate one of the following levels of maintenance.

<i>Code</i>	<i>Explanation</i>
0	Support item is removed, replaced, used at the organizational level of maintenance.

Note 2. A code "C" may be used in this position to denote crew or operator maintenance performed within organizational maintenance.

D..... Support items that are removed, replaced, used at depot only.

REPAIR (Fourth Position): The maintenance code entered in the fourth position indicates whether the item is to be repaired and identifies the lowest maintenance level will the capability to perform complete repair (i.e., all authorized

maintenance functions). The decision to code the support item for repair at the indicated maintenance levels requires that all maintenance capability (remove, replace, repair, assemble, and test) for the support items be provided to that level. This does not preclude some repair which may be accomplished at a lower level of maintenance. However, because of service differences in communicating maintenance repair level information a maintenance code entry in this position is not required by all services. When a maintenance code is not used a dash (-) sign will be entered. For multi-service equipment/systems or when a code is entered, this position will contain one of the following maintenance codes as assigned by the service(s) that require the code.

<i>Code</i>	<i>Application/Explanation</i>
F. . . .	The lowest maintenance level capable of complete repair of the support item is Direct Support.
Z....	Nonreparable. No repair is authorized.

(3) **Recoverability Code.** Recoverability Codes are assigned to support items to indicate the disposition action on unserviceable items. The recoverability code is entered in the fifth position of the uniform SMR Code Format as follows:

<i>Code</i>	<i>Application/Explanation</i>
Z. .	<i>Noreparable item.</i> When unserviceable, condemn and dispose at the level indicated in the first digit of the maintenance code.
D....	<i>Reparable item.</i> When beyond lower level repair capability, return to depot. Condemnation and disposal not authorized below depot level.

b. Federal Stock Number. Indicates the Federal stock number assigned to the item and will be used for requisitioning purposes.

c. Description. Indicates the Federal item name and a minimum description required to identify the item. The last line indicates the reference number followed by the applicable Federal Supply Code for Manufacturer (FSCM) in parentheses. The FSCM is used as an element in item identification to designate manufacturer or distributor *or* Government agency, etc, and is identified in SB 708-42.

d. Unit of Measure (U/M). Indicates the standard or basic quantity by which the listed item is used in performing the actual maintenance function. This measure is expressed by a two-character alphabetical abbreviation, e.g., ea, in, pr, etc, and is the basis used to indicate quantities and allowances in subsequent columns. When the unit of measure differs from the unit

of issue, the lowest unit of issue that will satisfy the required units of measure will be requisitioned.

e. Quantity Incorporated in Unit. Indicates the quantity of the item used in the breakout shown on the illustration figure, which is prepared for a functional group. Subfunctional group, or an assembly. A "V" appearing in this column in lieu of a quantity indicates that no specific quantity is applicable, e.g., shims, spacers, etc.

f. 15-Day Organizational Maintenance Allowances.

(1) The repair parts indicated by an asterisk in the allowance columns represent those authorized for use at the organizational category and will be requisitioned on an "as required" basis until stockage is based on demand in accordance with AR 710-2.

(2) Major Army commanders are authorized to approve reduction in range of support items authorized for use in units within their commands. Recommendation for increase in range of items authorized for use will be forwarded to the Commander, USA Electronics Command, Maintenance Directorate, AMSEL-MA-S, Fort Monmouth, N.J. 07703. Any changes approved will be reflected in a revision to the RPSTL.

(3) Allowance quantities are indicated in the Special Tools List section for special tools, TMDE, and other support equipment.

g. Illustration. This column is divided as follows:

(1) *Figure Number.* Indicates the figure number of the illustration on which the item is shown.

(2) *Item Number.* Indicates the item number used to reference the item on the illustration.

D-4. Special Information

a. Repair parts kits and gasket sets. Not applicable.

b. Applicable to revision and/or change only. Action change codes indicated in the left-hand margin of the listing page denote the following:

- N—Indicates an added item.
- C—Indicates a change in data.
- R—Indicates a change in FSN only.

c. The following additional publications per-

tain to Searchlight Set, Infrared AN/VSS-3A and its components:

TM 11-5855-217-35-1 - - - - - Direct Support, General Support, and Depot Maintenance Manual Including Repair Parts and Special Tools List.

D-5. How to Locate Repair Parts

a. When Federal stock number or reference number is unknown:

(1) *First.* Using the table of contents determine the functional group or functional subgroup within which the repair part belongs, i.e., Control Box, Remote Control box. This is necessary since illustrations are prepared for functional groups or functional subgroups, and listings are divided into the same groups.

(2) *Second.* Find the illustration covering the group or functional subgroup to which the repair part belongs.

(3) *Third.* Identify the repair part on the illustration and note the illustration figure and item number of the repair part.

(4) *Fourth.* Using the Repair Parts Listing, find the functional group or functional subgroup to which the repair part belongs and locate the illustration figure and item number noted on the illustration.

b. When Federal stock number or reference number is known:

(1) *First.* Using the Index of Federal Stock Numbers and Reference Numbers find the pertinent Federal stock number or reference number. This index is in ascending FSN sequence followed by a list of reference numbers in ascending alphameric sequence, cross-referenced to the illustration figure number and item number.

(2) *Second.* Using the Repair Parts Listing, find the functional group or functional subgroup of the repair part and the illustration figure number and item number referenced in the Index of Federal Stock Numbers and Reference Numbers.

(Next printed page is D-3.)

SECTION II REPAIR PARTS FOR ORGANIZATIONAL MAINTENANCE

(1) SMR CODE	(2) FEDERAL STOCK NUMBER	(3) DESCRIPTION REFERENCE NUMBER & MFR CODE	(4) UNIT OF MEAS	(5) QTY IN UNIT	(6) 15-DAY ORG MAINT ALLOWANCE				(7) ILLUSTRATIONS	
					(a) 1.5	(b) 8.20	(c) 21.60	(d) 51.100	(a) FIG NO	(b) ITEM NO OR REFERENCE DESIGNATION
	5855-177-3520	SEARCHLIGHT SET, INFRARED AN/VSS-3A (80058) (THIS ITEM IS NONEXPENDABLE)							1-1	
PAOZZ	5975-123-1527	COVER, SEARCHLIGHT SCD 647202 (80063)	EA	1	*	*	*	*	1-1	1
PAOFD	5855-177-3525	CONTROL, SEARCHLIGHT SET c 7905A/VSS-3 (80058)	EA	1	*	*	*	*	1-1	2
PAOFD	5855-177-3527	CONTROL, SEARCHLIGHT SET C 7906A/VSS-3 (80058)	EA	1	*	*	*	*	1-1	3
PAOZZ	6250-134-1757	EXTRACTOR ASSEMBLY, RSI SCD646613 (80063)	EA	1	*	*	*	*	1-1	4
PAOFD	5855-177-3528	SEARCHLIGHT, INFRARED MX8272A/VSS-3 (80058)	EA	1					1-1	5
PAOZZ	6240-155-7836	LAMP, INCANDESCENT MS25237 327 (96906)	EA	4	*	*	*	*	5-1	
PAOZZ	5920-280-8342	FUSE 313001 (75916)	EA	1	*	*	*	*	5-1	2
PAOZZ	6920793.4592	FUSE 313002 (75915)	EA	1	*	*	*	*	5-1	3
PAOZZ	6240-851-4352	LAMP, INCANDESCENT 330 (08806)	EA	1	*	*	*	*	5-1	4
PAOZZ	5340430.7049	COUPLING, CLAMP, GROOVED SCD646909 (80063)	EA	1	*	*	*	*	5-2	
PAOZZ	5855-135-0138	WINDOW 501-2439-401163003	EA	1	*	*	*	*	5-2	2
PAOZZ	5330-143-7718	SEAL, RUBBER CHANNEL 501-2479-401 (83003)	EA	1	*	*	*	*	5-2	3
PAOZZ	5999-134-5691	CLIP, LAMP SUPPORT 501-2412-401 (83003)	EA	1	*	*	*	*	5-2	6
PAOZZ	5305-064-6655	SCREW, MACHINE MS51957-31 (96906)	EA	4	*	*	*	*	5-2	9
PAOZZ	5310-929-6395	WASHER, LOCK MS35336 136 (96906)	EA	4	*	*	*	*	5-2	10
PAOZZ	5310-880-5976	WASHER, FLAT MS15795806 (96906)	EA	4	*	*	*	*	5-2	11
PAOZZ	5330-180-9890	GASKET SCC646964 (80063)	EA	1	*	*	*	*	5-2	12
PAOZZ	6250-134-1757	HOLDER, LAMP SCD646813 (80063)	EA	1	*	*	*	*	5-2	13
PAOZZ	6230-168-0153	LAMP AND HOLDER SCD646612 (80063)	EA	1	*	*	*	*	5-2	15
PAOZZ	5655-14.4949	INSTALLATION KIT, M551 SCD647132 (80063)	EA	1					E-3	
PAOZZ	5995-135-0081	CABLE ASSEMBLY, PWR CX-11893/VSS-3 (80058)	EA	1	*	*	*	*	E-3	
PAOZZ	5855-110-3541	PIN, QUICK RELEASE SCD646817 (80063)	EA	3	*	*	*	*	E-3	2
PAOZZ	5305-716-8186	SCREW, CAP, HEXAGON HEAD MS90726-110 (96906)	EA	4	*	*	*	*	E-3	3
PAOZZ	5310757.9425	WASHER, FLAT MS15795816 (96906)	EA	4	*	*	*	*	E-3	4
PAOZZ	5855-135-0162	SUPPORT, SEARCHLIGHT SCD646811 (80063)	EA	1	*	*	*	*	E-3	5
PAOZZ	5305-052-6456	SCREW, CAP, SOCKET HEAD MS16996 10 (96906)	EA	4	*	*	*	*	E-3	6
PAOZZ	5310-721-7809	WASHER, LOCK MS35340-43 (96906)	EA	4	*	*	*	*	E-3	7
PAOZZ	5305-269-2803	SCREW, CAP, HEXAGON HEAD MS90726-60 (96906)	EA	4	*	*	*	*	E-3	8
PAOZZ	5310-061-1258	WASHER, LOCK MS45904-76 (96906)	EA	4	*	*	*	*	E-3	9
PAOZZ	5855-114-4953	INSTALLATION KIT, M60 SCD647180 (80063)	EA	1					E-4	
FLIOFF	5855-114-4954	MOUNT ASSEMBLY, SEARCHLIGHT SCD647168 (80063)	EA	1	*	*	*	*	E-4	1

SECTION II REPAIR PARTS FOR ORGANIZATIONAL MAINTENANCE (CONTINUED)

(1) SMR CODE	(2) FEDERAL STOCK NUMBER	(3) DESCRIPTION REFERENCE NUMBER & MFR CODE	(4) UNIT OF MEAS	(5) QUAN- TITY INC IN UNIT	(6) 15-DAY ORG MAINT ALLOWANCE				(7) ILLUSTRATIONS	
					(a) 1-5	(b) 1-20	(c) 1-50	(d) 51-100	(a) FIG NO	(b) ITEM NO OR REFERENCE DESIGNATION
AOZZ	310-787-9425	WASHER, FLAT MS15795-818 (98906)	EA	4	*	.	.	.	E-4	2
AOZZ	305-725-4183	SCREW, CAP, HEXAGON HEAD MS90725-113 (98906)	EA	4	*	.	.	.	E-4	3
AOZZ	305-177-3562	CABLE ASSY, PWR SCD647380 (80083)	EA	1	*	.	.	.	E-4	4
AOZZ		WASHER, LOCK MS35338-46 (98906)	EA	4	*	.	.	.	E-4	5
AOZZ	305-288-3209	SCREW, CAP MS90725-58 (98906)	EA	4	*	.	.	.	E-4	6
AOZZ	310-891-1749	NUT, PLAIN, HEXAGON MS35891-17 (98906)	EA	4	*	.	.	.	E-4	7
AOZZ	305-995-3444	SCREW, MACHINE MS35208-268 (98906)	EA	4	*	.	.	.	E-4	8
AOZZ	310-045-3290	WASHER, LOCK MS35338-43 (98906)	EA	4	*	.	.	.	E-4	9
AOZZ	310-808-8546	WASHER, FLAT MS27183-3 (98906)	EA	4	*	.	.	.	E-4	10

**SECTION IV INDEX-FEDERAL STOCK NUMBER CROSS REFERENCE
TO FIGURE AND ITEM NUMBER OR REFERENCE DESIGNATION**

FEDERAL STOCK NUMBER			FEDERAL STOCK NUMBER			
FEDERAL STOCK NUMBER	FIGURE NUMBER	ITEM NUMBER OR REF DESIGNATION	FEDERAL STOCK NUMBER	FIGURE NUMBER	ITEM NUMBER OR REF. DESIGNATION	
			REFERENCE NO.	MFG. CODE	FIG. No.	ITEM No.
C 5305-052-6456	E-3	6				
5305-054-6655	5-2	9	AN/VSS-3A	80058	1-1	-
C 5305-269-2803	E-3	8	C MX-8272A/VSS-3	80058	1-1	5
N 5305-269-3209	E-4	6	C-7S05A/VSS-3	80058	1-1	2
5305-716-8186	E-3	3	C C-7906A/VSS-3	80058	1-1	3
N 5305-725-4183	E-4	3	CX-11893/VSS-3	80058	E-3	1
N 5303-995-3444	E-4	8	313001	75915	5-1	2
N 5310-004-5033	E-4	5	313002	75915	5-1	3
N 5310-045-3296	E-4	9	330	08806	5-1	4
C 5310-061-1258	E-3	9	501-2412-401	83003	5-2	8
C 5310-721-7809	E-3	7	501-2439-401	83003	5-2	2
N 5310-809-8546	E-4	10	501-2479-401	83003	5-2	3
5310-880-5976	5-2	11	MS15795-806	96906	5-2	11
5310-767-9425	E-3	4	MS15795-818	96906	E-3	4
N 5310-767-9425	E-4	2	N MS15795-818	96906	E-4	2
N 5310-809-8546	E-4	10	C MS16996-10	96906	E-3	6
N 5310-891-1749	E-4	7	MS25237-327	96906	5-1	1
5310-929-6395	5-2	10	N MS27183-8	96906	E-4	10
5330-143-7718	5-2	3	N MS35206-266	96906	E-4	8
5330-180-9890	5-2	12	MS35338-136	96906	5-2	10
5340-030-7049	5-2	1	N MS35338-43	96906	E-4	9
5865-110-3541	E-3	2	N MS35338-46	96906	E-4	5
5855-114-494	E-3	-	C MS35340-43	96906	E-3	7
N 5855-114-49	E-4	-	N MS35691-17	90906	E-4	7
N 5855-114-4954	E-4	1	C MS45904-76	90906	E-3	9
5855-135-0138	5-2	2	MS51957-31	90906	5-2	9
5855-135-0162	E-3	5	N MS907265-58	90906	E-4	6
5855-177-3525	1-1	2	MS90726-110	90906	E-3	3
C 5855-177-3527	1-1	3	N MS90728-113	90906	E-4	3
C 5855-177-3528	1-1	5	C MS90728-60	90906	E-3	8
5855-177-3529	1-1	-	SC-C-64964	80083	5-2	12
5920-280-8342	5-1	2	SC-D-648811	80083	E-3	5
5920-793-4592	5-1	3	SC-D-646812	80063	5-2	15
5975-123-1527	1-1	1	N SC-D-646813	80063	1-1	4
5995-135-0081	E-3	1	N SC-D-646813	80063	5-2	13
N 5995-177-3562	E-4	4	SC-D-646817	80063	E-3	2
5999-134-5891	5-2	8	SC-D-646909	80063	5-2	1
6230-168-0153	5-2	15	SC-D-647132	80063	E-3	-
6240-155-7836	5-1	1	N SC-D-647168	80063	E-4	1
6240-851-4352	5-1	4	N SC-D-647180	80063	E-4	-
N 6250-134-1757	1-1	4	SC-D-647202	80063	1-1	1
6250-134-1757	5-2	13	N SC-D-647380	80063	E-4	4

APPENDIX E

AN/VSS-3A FSN 5855-405-0404
 ORGANIZATIONAL MAINTENANCE REPAIR PARTS AND
 SPECIAL TOOLS LIST

SECTION I. INTRODUCTION

E-1. SCOPE

This appendix lists repair parts and special tools required for the performance of organizational maintenance of the AN/VSS-3A, Federal Stock Number 5855-405-0404.

Code	Explanation
PA ----	Item procured and stocked for anticipated or known usage.

E-2. General

This repair parts and special tools list is divided into the following sections:

PC-----	Item procured and stocked and which otherwise would be coded PA except that it is deteriorative in nature.
---------	--

a. Repair Parts – Section II. A list of repair parts authorized for the performance of maintenance at the organizational level. The list also includes parts which must be removed for the replacement of the authorized parts.

PD ----	Support item, excluding support equipment, procured for initial issue or outfitting and stocked only for subsequent or additional initial issues or outfittings. Not subject to automatic replenishment.
---------	--

b. Special Tools, Test and Support Equipment – Section III. Not applicable.

c. Federal Stock Number and Reference Number Index – Section IV. A list, in ascending numerical sequence, of all Federal stock numbers appearing in the listings, followed by a list, in alpha-numeric sequence, of all referenced numbers appearing in the listings. Federal stock numbers and reference numbers are cross-referenced to each illustration figure number and item number appearance.

E-3. Explanation of Columns

The following provides an explanation of columns found in the tabular listings:

a. Source, Maintenance, and Recoverability Codes(SMR).

(1) Source code. Indicates the manner of acquiring support items for maintenance, repair, or overhaul of end items. Source codes are:

USE (THIRD POSITION): The maintenance code entered in the third position will indicate the lowest maintenance level authorized to remove, replace, and use the support item. The decision to code the item for removal and replacement at the indicated maintenance level will require that all the capabilities necessary to install and insure proper operation after installation of a replacement item (i.e., preinstallation inspection, testing and post-installation checkout) are provided. The maintenance code entered in the third position will indicate one of the following levels of maintenance.

Code	Application/Explanation
0 -----	Support item is removed, replaced, used at the organizational level of maintenance. Note 2. A code "C" may be used in this position to denote crew or operator maintenance performed within organizational maintenance,

XA ----- Item is not procured or stocked because the requirements for the item will result in the replacement of the next higher assembly.

REPAIR (FOURTH POSITION): The maintenance code entered in the fourth position indicates whether the item is to be repaired and identifies the lowest maintenance level with the capability to perform complete repair (i.e., all authorized maintenance functions). The decision to code the support item for repair at the indicated maintenance levels requires that all maintenance capability (remove, replace, repair, assemble, and test) for the support items be provided to that level. This does not preclude some repair which may be accomplished at a lower level of maintenance. However, because of service differences in communicating maintenance repair level information a maintenance code entry in this position is not required by all services. When a maintenance code is not used a dash (-) sign will be entered. For multi-service equipment/systems or when a code is entered, this

NOTE 1. Cannibalization or salvage maybe used as a source of supply for any items source coded above except those coded XA and aircraft support items as restricted by AR 700-42.

(2) Maintenance Code. Maintenance codes are assigned to indicate the levels of maintenance authorized to USE and REPAIR support items. The maintenance codes are entered in the third and fourth positions of the Uniform SMR Code Format as follows:

position will contain one of the following maintenance codes as assigned by the service(s) that require the code:

Code	Application/Explanation
F -----	The lowest maintenance level capable of complete repair of the support item is Direct Support.

Z ----- Nonrepairable. No repair is authorized.

(3) Recoverability Code.

Recoverability Codes are assigned to support items to indicate the disposition action on unserviceable items. The recoverability code is entered in the fifth position of the uniform SMR Code Format as follows:

Code	Application/Explanation
Z - - - -	Nonrepairable item. When unserviceable, condemn and dispose at the level indicated in the first digit of the maintenance code.

D ----- Repairable item. When beyond lower level repair capability, return to de-

pot. Condemnation and disposal not authorized below depot level.
 L ----- Repairable item. Repair condemnation and disposal not authorized below/ Specialized Repair Activity level.
 A ----- Item requires special handling or condemnation procedures because of specific reasons (i.e., precious metal content, high dollar value, critical material or hazardous material).

b. Federal Stock Number. Indicates the Federal stock number assigned to the item and will be used for requisitioning purposes.

c. Description. Indicates the Federal item name and a minimum description required to identify the item. The last line indicates the reference number followed by the applicable Federal Supply Code for Manufacturer (FSCM) in parentheses. The FSCM is used as an element in item identification to designate manufacturer, distributor or Government agency etc., and is identified in SB 708-42.

d. Unit of Measure. Indicates the standard or basic quantity by which the listed item is used in performing the actual maintenance function. This measure is expressed by a two character alphabetical abbreviation, eg., ea., in., pr., etc. When the unit of measure differs from the unit of issue, the lowest unit of issue that will satisfy the required units of measure will be requisitioned.

e. Quantity Incorporated in Unit. Indicates the quantity of the item used in the breakout shown on the illustration figure, which is prepared for a functional group, subfunctional group, or an assembly. A "V" appearing in this column in lieu of a quantity indicates that no specific quantity is applicable, e.g., shims, spacers, etc.

f. 15-Day Organizational Maintenance Allowances.

(1) The repair parts indicated by an asterick in the allowance columns represent those authorized for use at the organizational category and will be requisitioned on an "as required" basis until stockage is based on demand in accordance with AR 710-2.

(2) Major Army commanders are authorized to approve reduction in range of support items authorized for use in units within their commands. Recommendation for increase in range of item authorized for use will be forwarded to the Commander, USA Electronics Command, Maintenance Directorate, AMSEL-MA-S, Fort Monmouth, N.J. 07703. Any changes approved will be reflected in a revision to the RPSTL.

(3) Allowance quantities are indicated in the Special Tools List section for Special tools, TMDE, and other support equipment.

g. Illustration. This column is divided as follows.

(1) Figure Number. Indicates the figure number of the illustration on which the item is shown.

(2) Item Number. Indicates the item number used to reference the item on the illustration.

E-4. Special Information.

a. Repair parts and gasket sets. Not Applicable

b. Applicable to revision and/or change only. Action change codes indicated in the left-hand margin of the listing page denote the following;

N - Indicates an added item.

C - Indicates a change in data.

R - Indicates a change in FSN only.

c. The following additional publications pertain to Searchlight Set,

Change 5

E-4

Infrared AN/VSS-3A and its components:
TM 11-5855-217-35-1- Direct Support, General Support, and Depot Maintenance Manual Including Repair Parts and Special Tools List.

E-5. How to Locate Repair Parts

a. When Federal stock number or reference number is unknown:

(1) *First.* Using the table of contents determine the functional group or functional subgroup within which the repair part belongs, i.e., Control Box, Remote Control, Box. This is necessary since illustrations are prepared for functional groups or functional subgroups, and listings are divided into the same groups.

(2) *Second.* Find the illustration covering the group or functional subgroup to which the repair part belongs.

(3) *Third.* Identify the repair part on the illustration and note the illustration figure and item number of the repair part.

(4) *Fourth.* Using the Repair Parts Listing, find the functional group or functional subgroup to which the repair part belongs and locate the illustration figure and item number noted on the illustration.

b. When Federal stock number or reference number is known:

(1) *First.* Using the Index of Federal Stock Numbers and Reference Numbers find the pertinent Federal stock number or reference number. This index is in ascending FSN sequence followed by a list of reference numbers in ascending alphameric sequence, cross-referenced to the illustration figure number and item number.

(2) *Second.* Using the Repair Parts Listing, item the functional group or functional subgroup of the repair part and the illustration figure number and item number referenced in the Index of Federal Stock Numbers and Reference Numbers.

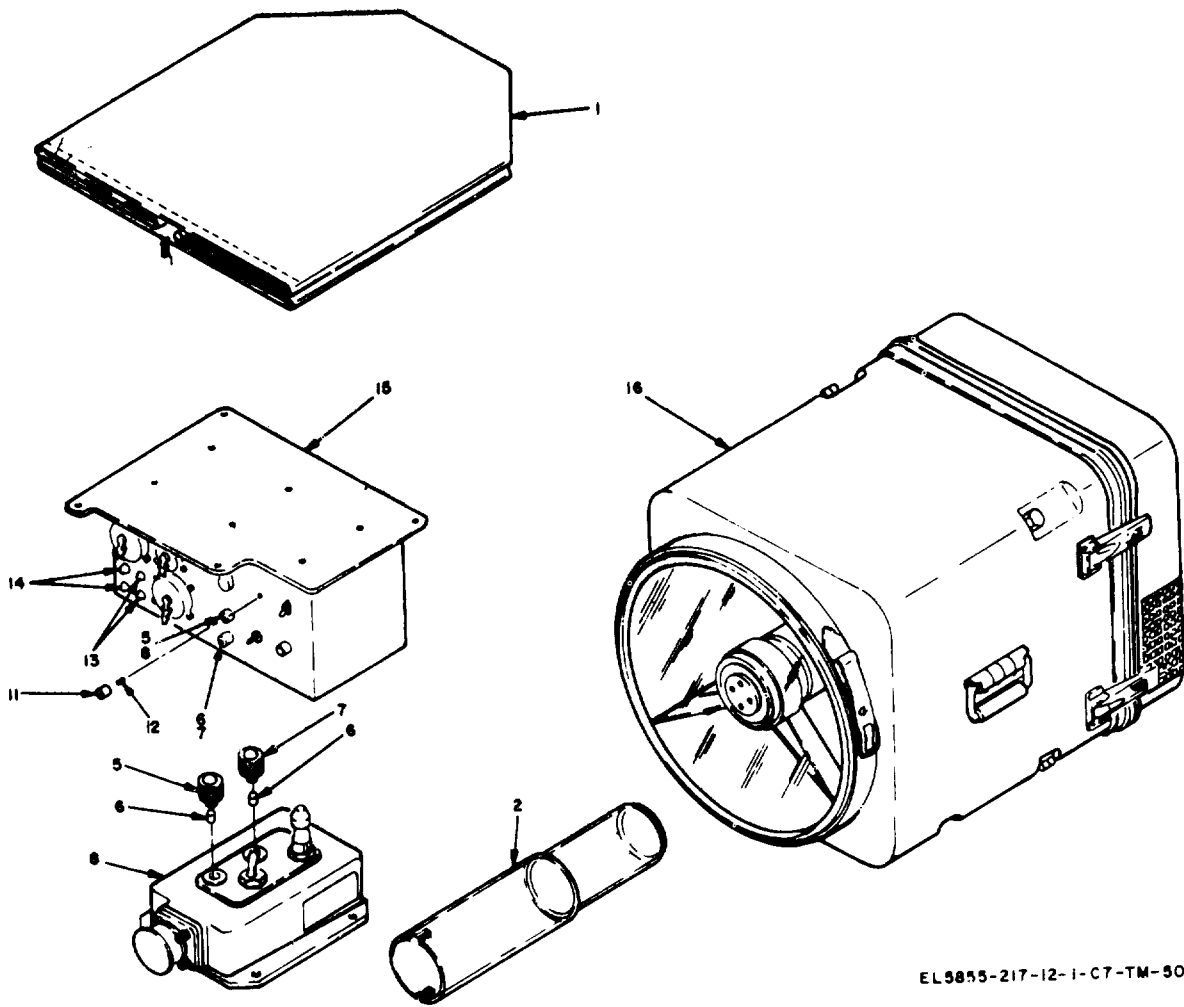

EL 5855-217-12-1-C7-TM-50

Figure E-1. Infrared Searchlight Set AN/VSS-3 (A).

SECTION II REPAIR PARTS FOR ORGANIZATIONAL MAINTENANCE

(1) PART CODE	(2) FEDERAL STOCK NUMBER	(3) DESCRIPTION REFERENCE NUMBER & MFR CODE	(4) QUANTITY OF IEA	(5) UNIT OF MEASURE	(8) 15-DAY ORG MAINT ALLOWANCE				(6) FIGURE	(7) ILLUSTRATIONS	
					(a) 1-5	(b) 6-20	(c) 21-50	(d) 51-100		(a) FIGURE	(b) ITEM NO OR REFERENCE DESIGNATION
		SEARCHLIGHT SET, INFRARED AN/VSS-3(A)									
'AOZZ'	975-123-1527	COVER ASSEMBLY, SEARCHLIGHT SCD647202-1 (80063)	E	1	*	*	*	*	E-1		1
'AOZZ'	250-134-1757	EXTRACTOR ASSEMBLY, RS1 SCD646813 (80063)	E	1	*	*	*	*	E		2
'AOZZ'	210-022-7981	LENS, INDICATOR LIGHT LC37RD2 (81349)	E	2	*	*	*	*	E-1		5
'AOZZ'	240-155-7836	LAMP, INCANDESCENT MS25237-327 (96906)	E	4	*	*	*	*	E-1		6
'AOZZ'	210-022-7980	LENS, INDICATOR LIGHT LC37GD2 (81349)	E	2	*	*	*	*	E-1		7
'AOFI'	855-451-5224	CONTROL, SCHLT SET, C7906(B)/VSS-3 SCD646802-1 (80063)	E	1	*	*	*	*	E-1		8
'AOZZ'	210-464-0447	LENS, INDICATOR LIGHT LC37CD21613491	E	1	*	*	*	*	E-1		11
'AOZZ'	240-851-4352	LAMP, INCANDESCENT MS25237-330 (96906)	E	1	*	*	*	*	E-1		12
'AOZZ'	920-199-9498	FUSE, CARTRIDGE F02B125V12A (813491)	E	2	*	*	*	*	E-1		13
'AOZZ'		FUSE, CARTRIDGE F02A125V2A (81349)	E	2	*	*	*	*	E-1		14
'AOFI'	855-189-6065	CONTROL, SCHLT. C7905(B)/VSS-3 SCD647251.1 (80063)	E	1	*	*	*	*	E-1		15
'DOFI'	855-189-6066	SEARCHLIGHT, IR, MX8272(B)/VSS-3 SCD647252-1 (80063)	E	1	*	*	*	*	E-1		16

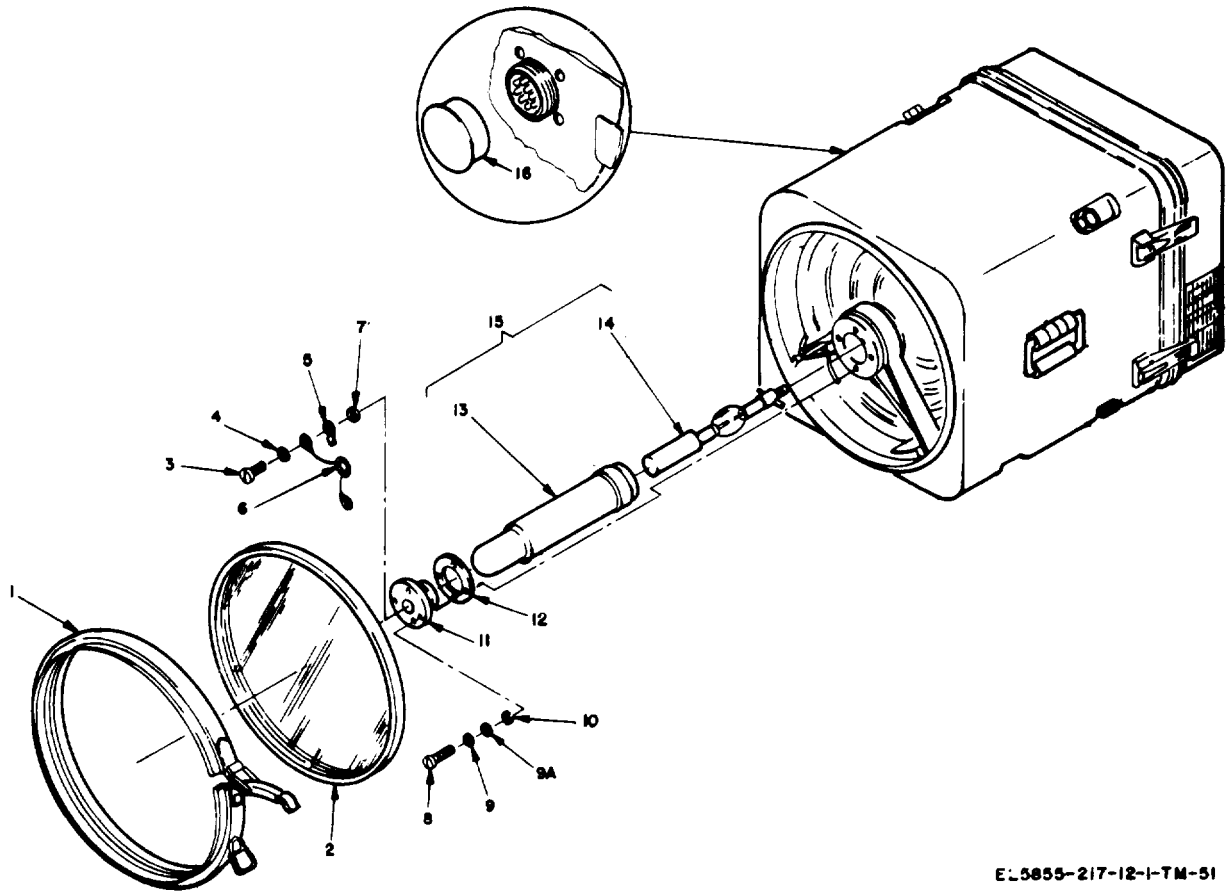

E-5855-217-12-1-TM-51

Figure E-2. Searchlight, Infrared MX8272B/VSS-3.

SECTION II REPAIR PARTS FOR ORGANIZATIONAL MAINTENANCE

(1) SMR CODE	(2) FEDERAL STOCK NUMBER	(3) DESCRIPTION REFERENCE NUMBER & MFR CODE	(4) UNIT OF MEAS	(5) QTY /WG IN UNIT	(6) 15-DAY ORG MAINT ALLOWANCE				(7) ILLUSTRATIONS	
					a) 5	b) 20	c) 21-50	d) 51-100	(a) FIG NO	(b) ITEM NO OR REFERENCE DESIGNATION
		SEARCHLIGHT, INFRARED MX8272(B)/VSS-3								
PAQZZ	5340-030-7049	COUPLING, CLAMP, GROOVED SCD646909 (80063)	A	1					E-2	1
PA02Z	5865-004-0903	WINDOW ASSEMBLY, SEARCHLIGHT SCD348914 1 (80063)	A	1					E-2	2
PA0ZZ	5305-054-3652	SCREW, MACHINE NS151957-28 (98906)	A	1					F-2	3
PA02Z	5310-722-5998	WASHER, FLAT NS15795-805 (98906)	A	1					E-2	4
PA02Z	5940-113-9824	TERMINAL LUG NS20659 107 (98906)	A	1					E-2	5
PA02Z	5910-008-7436	CAPACITOR ASSEMBLY SCC647122-1 (80063)	A	1					E-2	6
PA02Z	5365-2345147	PACER, RING 8731 (83330)	A	1					E-2	7
PA0ZZ	5305-150-4794	SCREW, PANEL, CAPTIVE 6130SS0632-7 (06540)	A	4					E-2	6
PA0ZZ	5310-929-6395	WASHER, LOCK NS55338-138 (98906)	A	4					F-2	6
PA0ZZ	5310-	WASHER, CAPTIVE 66647101 (80063)	A	1					F-2	8A
PA0ZZ	5970-496-0664	WASHER, RETAINING SC6647277 1 (90063)	A	4					F-2	10
PA0ZZ	5865-003-3230	LIP, FRONT LAMP SUPPORT SCD646962-1 (80063)	A	1					F-2	11
PA0ZZ	5330-180-9890	BASKET SCc546964 (80063)	A	1					F-2	12
PA0ZZ	6250-134-1757	EXTRACTOR ASSEMBLY, RSI SCD646813 (80063)	A	1					F-2	13
XA02Z	5855	LAMP, XENON SCD646831 (80063)	A	1					F-2	14
PA0ZZ	6230-168-0153	LAMP AND EXTRACTOR ASSEMBLY SCD6464812 (80063)	A	1					F-1	15
PA0ZZ	5340-687 1148	LAMP, DUST NS25178-32	A	1					F-2	16

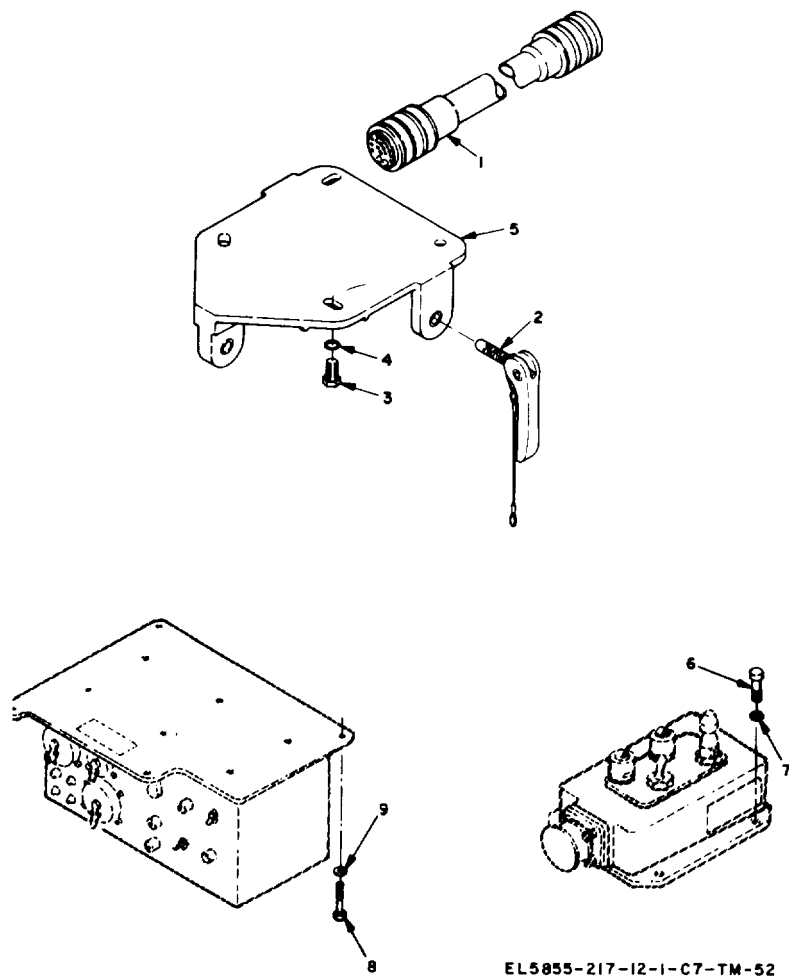

EL5855-217-12-1-C7-TM-52

Figure E-3. Adapter Kit M-551.

SECTION II REPAIR PARTS FOR ORGANIZATIONAL MAINTENANCE

(1) SMR ODE	(2) FEDERAL STOCK NUMBER	(3) DESCRIPTION REFERENCE NUMBER & MFR CODE	(4) UNIT OF MEAS	(5) QTY INC IN UNIT	(6) 15-DAY ORG MAINT ALLOWANCE				(7) ILLUSTRATIONS	
					(a) 1-5	(b) 6-20	(c) 21-50	(d) 51-111	(a) FIG NO	(b) ITEM NO OR REFERENCE DESIGNATION
		ADAPTER KIT. M-551								
.OZZ	5895-135-0081	CABLE ASSEMBLY, PWR. CX-11893/VSS-3 SCD646803-1 (80063)	EA	1	*	*	*	*	E-3	1
.OZZ	5855-110-3541	PIN, QUICK RELEASE SCD646817 (80063)	EA	3	*	*	*	*	E-3	2
.OZZ	5305-716-8186	SCREW, CAP, HEXAGON HEAD MS90726-110 (96906)	EA	4	.	*	.	.	E-3	3
.OZZ	5310-767-9425	WASHER, FLAT MS15795-818 (96906)	EA	4	.	*	.	*	E-3	4
.OZZ	5655135.0152	MOUNT ASSEMBLY, SEARCHLIGHT SC064661 1.1 (80063)	EA	1	.	.	*	.	E-3	5
.OZZ	5306-052-6456	SCREW, CAP, SOCKET HEAD MS16996-10 (96906)	EA	4	*	*	*	*	E-3	5
.OZZ	5310-721-7809	WASHER, LOCK MS35340-43 (96906)	EA	4	*	.	.	.	E-3	7
N .OZZ	5306-269-2803	SCREW, CAP, HEXAGON HEAD MS90726-60 (96906)	EA	4	.	.	.	*	E-3	6
N .OZZ	5310-061-1256	WASHER, LOCK MS45904-76 (96906)	EA	4	.	.	.	*	E-3	9

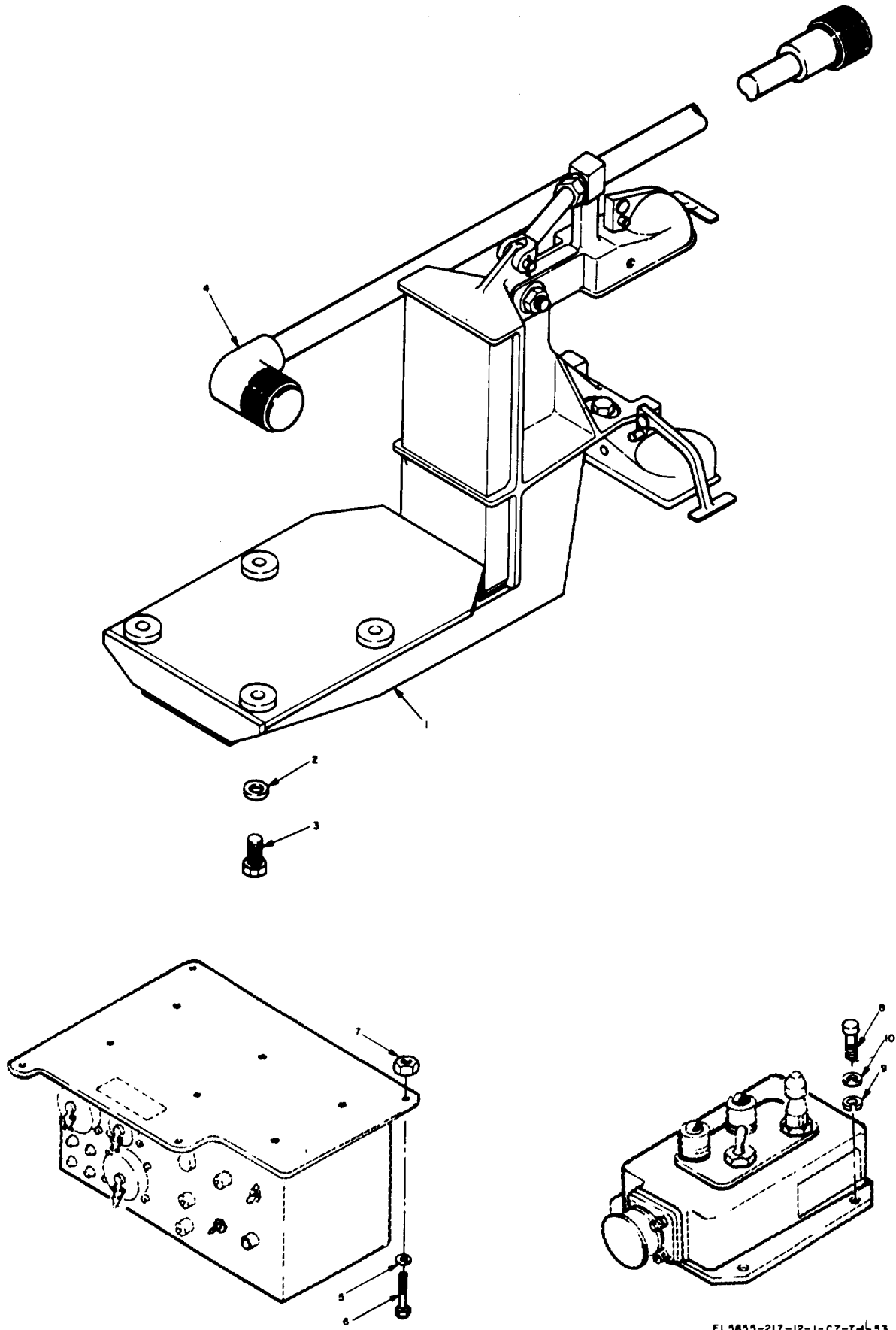

EL5855-217-12-1-C7-TM-53

Figure E-4. Adapter Kit M-60.

SECTION II REPAIR PARTS FOR ORGANIZATIONAL MAINTENANCE

(1) MFR DDE	(2) FEDERAL STOCK NUMBER	(3) DESCRIPTION REFERENCE NUMBER & MFR CODE	(4) UNIT OF MEAS	(5) QTY INC IN UNIT	(6) 15-DAY ORG MAINT ALLOWANCE				(7) ILLUSTRATIONS	
					(a) 1-5	(b) 6-20	(c) 21-50	(d) 51-100	(a) FIG NO	(b) ITEM NO OR REFERENCE DESIGNATION ¹
		ADAPTER KIT, M-60								
O F F	5855-114-4954	MOUNT ASSEMBLY, SCHLT, M-60 SCD847188-1 (80063)	EA	1	*	*	*	*	E-4	1
.OZZ	5310-767-9425	WASHER, FLAT MS15795-818 (96906)	EA	4	*	*	*	*	E-4	2
.OZZ	5305-725-4183	SCREW, CAP, HEXAGON HEAD MS80728-113 96906	EA	4	*	*	*	*	E-4	3
.OZZ	5995-177-3562	CABLE ASSY, PWR, CX11883/VSS-3 SCD847380 80063	EA	1	*	*	*	*	E-4	4
N	.OZZ	5310-004-5033	WASHER, LOCK MS35338-46 (96906)	EA	4	*	*	*	E-4	5
N	.OZZ	5306-288-3208	SCREW, CAP MS90725-58 (96906)	EA	4	*	*	*	E-4	6
N	.OZZ	5310-891-1749	NUT, PLAIN, HEXAGON MS35891-17 (96906)	EA	4	*	*	*	E-4	7
N	.OZZ	6305-986-4444	SCREW, MACHINE MS35206-268 (96906)	EA	4	*	*	*	E-4	8
N	.OZZ	5310-045-3286	WASHER, LOCK MS35338-47 (96906)	EA	4	*	*	*	E-4	9
N	PAOZZ	5310-808-8546	WASHER, FLAT MS27183-8 (96906)	EA	4	*	*	*	E-4	10

SECTION IV INDEX-FEDERAL STOCK NUMBER CROSS REFERENCE
TO FIGURE AND ITEM NUMBER OR REFERENCE DESIGNATION

FEDERAL STOCK NUMBER	FIGURE NUMBER	ITEM NUMBER OR REF. DESIGNATION	FEDERAL STOCK NUMBER	FIGURE NUMBER	ITEM NUMBER OR REF. DESIGNATION
C 5305-062-6456	E-3	6	6250-134-1757	E-2	13
5305-054-8852	E-2	3			
5305-150-4794	E-2	8			
C 5305-269-2803	E-3	8	<u>REFERENCE NUMBER</u>	<u>MFG. CODE</u>	<u>FIGURE NUMBER</u>
N 5305-269-3209	E-4	6	F02A125V2A	81349	E-1 14
5305-716-8186	E-3	3	F02B125V1-2A	81349	E-1 13
5305-725-4183	E-4	3	LC37CD2	81349	E-1 11
N 5305-995-3444	E-4	8	LC37GD2	81349	E-1 7
5310-	E-2	9A	LC37RD2	81349	E-1 5
N 5310-004-5033	E-4	5	MS15795-805	96906	E-2 4
N 5310-045-3296	E-4	9	MS15795-818	96906	E-3 4
C 5310-061-1258	E-3	9	MS15795-818	96906	E-4 2
C 5310-721-7809	E-3	7	C MS16996.10	96906	E-3 6
5310-722-5998	E-2	4	MS20659-107	96906	E-2 5
5310-787-9425	E-3	4	MS25178-32	96906	E-2 16
5310-767-9425	E-4	2	MS25237-327	96906	E-1 6
N 5310-809-8546	E-4	10	MS25237-330	96906	E-1 12
N 5310-891-1749	E-4	7	N MS27183-8	96906	E-4 10
5310-929-6395	E-2	9	N MS35206-266	96906	E-4 8
5310-180-9890	E-2	12	MS35338-139	96906	E-2 9
5330-030-7049	E-2	1	N MS35338-43	96906	E-4 9
5340.687-1148	E-2	16	N MS35338-46	96906	E-4 5
5385-234-5147	E-2	7	C MS36340-43	96906	E-3 7
5855-	E-2	14	N MS35691-17	96906	E-4 7
5855-003-3230	E-2	11	C MS45904-76	96906	E-3 9
5855-004-0903	E-2	2	MS51957-28	96906	E-2 3
5855-110-3541	E-3	2	N MS90725-58	96906	E-4 6
5855-114-4949	E-3	-	MS90726-110	96906	E-3 3
5855-114-4953	E-4	-	MS90726-113	96906	E-4 3
5855-114-4954	E-4	1	C MS90726-60	96906	E-3 8
5855-135-0162	E-3	5	SC8647181	80063	E-2 9A
5855-189-6065	E-1	15	SC8647277-1	80063	E-2 10
5855-189-6066	E-1	16	SCC640964	80063	E-2 12
5855-451-5224	E-1	8	SCC647122-1	80063	E-2 6
5910-008-7436	E-2	6	SCC647122-1	80063	E-1 8
5920-199-9498	E-1	13	SCD646802-1	80063	E-3 1
5920-	E-1	14	SCD646811-1	80063	E-3 5
5940-113-9824	E-2	5	SCD646812	80063	E-2 15
5970-486-0564	E-2	10	SCD646813	80063	E-1 2
5975-123-1527	E-1	1	SCD646813	80063	E-2 13
5905-136-0081	E-3	1	SCD646817	80063	E-3 2
5995-177-3562	E-4	4	SCD646909	80063	E-2 1
6210-022-7980	E-1	7	SCD646914-1	80063	E-2 2
6210-022-7981	E-1	5	SCD646931	80063	E-2 14
6210-464-0447	E-1	11	SCD646962-1	80063	E-2 11
6230-168-0153	E-2	15	SCD647132-1	80063	E-3 -
6240-155-7836	E-1	6	SCD647168-1	80063	E-4 1
6240-851-4362	E-1	12	SCD647180-1	80063	E-4 -
6250-134-1757	E-1	2	SCD647202-1	80063	E-1 1
			SCD647251-1	80063	E-1 15

SECTION IV INDEX-FEDERAL STOCK NUMBER CROSS REFERENCE
 TO FIGURE AND ITEM NUMBER OR REFERENCE DESIGNATION (CONTINUED)

FEDERAL STOCK NUMBER	FIGURE NUMBER	ITEM NUMBER OR REF. DESIGNATION	FEDERAL NUMBER	FIGURE NUMBER	ITEM NUMBER OR REF. DESIGNATION
SCD647252-1	80063	E-1			16
SCD64380	80063	E-4			4
6130SS0632-7	06540	E-2			8
8731	83330	E-2			7

I N D E X

	Paragraph	Page
Additional equipment required- - - - -	1-10	1-3
Adjustments, beam width - - - - -	3-7	3-3
Arctic climates, operation- - - - -	3-12	3-4
Authority, demolition - - - - -	6-4	6-1
Beam width adjustment - - - - -	8-7	3-3
Characteristics, technical - - - - -	1-5	1-1
Charts:		
Operator's weekly preventive maintenance checks and services- - - - -	4-5	4-1
Organizational monthly preventive maintenance checks and services - - - - -	5-3	5-1
Checking unpacked equipment - - - - -	2-2	2-1
Checks and services required- - - - -	4-4	4-1
Cleaning procedures:		
Operator's - - - - -	4-6	4-3
Organizational - - - - -	5-5	5-2
Components, table - - - - -	1-6	1-2
Control box, replacement - - - - -	5-15	5-8
Control settings, preliminary - - - - -	3-5	3-2
Controls, searchlight - - - - -	6-3	6-1
Demolition, authority - - - - -	6-3	6-1
Description:		
Equipment - - - - -	1-8	1-2
Minor components - - - - -	1-9	1-3
Desert climates, operation - - - - -	3-14	3-4
Destruction:		
Methods - - - - -	6-6	6-1
Plan - - - - -	6-5	6-1
Disassembly - - - - -	6-1	6-1
Disposal, methods - - - - -	6-7	6-2
Equipment:		
Description - - - - -	1-8	1-3
Required, additional - - - - -	1-10	1-3
Emergency stopping procedure - - - - -	3-10	3-4
Exchanger, heat - - - - -	3-4	3-2
Fording - - - - -	3-11	3-4
Forms and records - - - - -	1-3	1-1
Functional names - - - - -	1-7	1-2
Fuses, replacement - - - - -	5-10	5-5
General:		
Organizational troubleshooting and repairs - - - - -	5-6	5-3
Heat exchanger - - - - -	8-4	3-2
Indices of publications - - - - -	1-2	1-1
Indicator lamps, replacement - - - - -	5-9	5-5
Indicators, searchlight - - - - -	3-2	3-2
Limited storage shipment - - - - -	6-3	6-1
Lubrication - - - - -	4-7	4-3
Materials required for operator maintenance - - - - -	4-2	4-1
Methods:		
Destruction - - - - -	6-6	6-1
Disposal - - - - -	6-7	6-2
Minor components, description - - - - -	1-9	1-3

	Paragraph	Page
Modes, operation	3 - 8	3 - 3
Monthly maintenance, organizational	5 - 3	5 - 1
Names, functional	1 - 7	1 - 2
Normal stopping procedure	3 - 9	3 - 4
Operation:		
Arctic climates	3-12	3 - 4
Desert climates	3-14	3 - 4
Modes	3-8	3 - 3
Tropical climates	3-13	3 - 4
Under saltwater spray environment	3-15	3 - 5
Operator maintenance:		
Cleaning procedures	4-6	4 - 2
Materials required	4-4	4 - 1
Preventive maintenance	4-8	4 - 1
Scope	4-1	4 - 1
Troubleshooting chart	4-8	4 - 3
Troubleshooting procedures	4-8	4 - 3
Weekly preventive maintenance checks and service chart	4-5	4 - 1
Organizational maintenance:		
Cleaning procedures	5-5	5 - 2
Monthly preventive maintenance checks and service chart	5-3	5 - 1
Preventive maintenance	5-3	5 - 1
Scope	5-1	5 - 1
Tools and materials required	5-2	5 - 1
Troubleshooting chart	5-7	5 - 3
Painting and refinishing procedure	5-4	5 - 2
Plan, destruction	6-5	6 - 1
Power cable, replacement	5-10	5 - 5
Preliminary control settings	3-6	3 - 2
Preventive maintenance:		
Operator's	4-3	4 - 1
Organizational	5-3	5 - 1
Procedure:		
Emergency stopping	3-10	3 - 4
Normal stopping	3-9	3 - 4
Painting and refinishing	5-4	5 - 2
Starting	3-6	3 - 2
Publications, indexes	1-2	1 - 1
Purpose and use (fig. 1-1)	1-4	1 - 1
Records, forms	1-3	1 - 1
Remote control box, replacement	5-16	5 - 8
Replacement:		
Control box	5-15	5 - 8
Fuses	5-8	5 - 4
Indicator lamps (fig. 5-3)	5-9	5 - 5
Power cable	5-10	5 - 5
Remote control box	5-16	5 - 8
Searchlight	5-13	5 - 6
Searchlight mount	5-14	5 - 7
Window	5-11	5 - 5
Xenon lamp	5-12	5 - 6
Required checks and services	4-4	4 - 1
Salt water spray environments, operation	3-15	3 - 5
Searchlight:		
Controls	3-1	3 - 1
Indicators	3-2	3 - 2
Mount, replacement	5-14	5 - 7
Replacement	5-13	5 - 6
Servicing	2-10	2 - 5
Shipment, limited storage	6-3	6 - 1
Starting procedure	3-6	3 - 2

	Paragraph	Page
Table, components	1-6	1-2
Technical characteristic	1-5	1-1
Tools and materials required, organizational maintenance	5-2	5-1
Tropical climate operation	3-13	3-4
Troubleshooting chart		
Operator	4-8	4-3
Organizational	5-7	5-3
Procedures, operator	4-8	4-3
Unpacked equipment checking	2-2	2-1
Unpacking	2-1	2-1
Window, replacement	5-11	5-5
Xenon lamp, replacement	5-12	5-6

By Order of the Secretary of the Army

W.C. WESTMORELAND,
General, United States Army
Chief of Staff

Official:

KENNETH G. WICKHAM,
Major General, United States Army
The Adjutant General

Distribution:

Active Army:

USASA (2)	Army Deps (1) except
CNGB (1)	LEAD (3)
USACDCCEA (1)	TOAD (5)
USACDCCEA	SAAD (5)
Ft Huachuca (1)	ATAD (5)
USAMB (10)	Gen Deps (2)
USAARENBD (2)	Sig Dep (3)
USAMC (1)	Sig Sec Gen Depa (3)
USCONARC (5)	MAAG (1)
OS Maj comd (5)	USARMIS (1)
LOGCOMD (2) except	Units org under fol TOE:
1st LOGCOMD (10)	(2 copies each)
9th LOGCOMD (10)	11-156
USAECOM (10)	11-500 (AA-AC)
Armies (5) except	17
Eighth (15)	17-15
USARV (20)	17-16
USAARMS (30)	17-17
USAOC&S (5)	17-37
USAFAS (30)	17-42
USAIS (30)	17-51
USAES (5)	37
USATC Armor (5)	37-100
USACDCEC (10)	37-102
Sig FLDMS (1)	

NG: State AC (3).

USAR: None.

For explanation of abbreviations used, see AR 310-50.

RECOMMENDED CHANGES TO EQUIPMENT TECHNICAL PUBLICATIONS



THEN...JOT DOWN THE DOPE ABOUT IT ON THIS FORM. CAREFULLY TEAR IT OUT, FOLD IT AND DROP IT IN THE MAIL.

SOMETHING WRONG WITH PUBLICATION

FROM: (PRINT YOUR UNIT'S COMPLETE ADDRESS)

DATE SENT

PUBLICATION NUMBER

PUBLICATION DATE

PUBLICATION TITLE

BE EXACT PIN-POINT WHERE IT IS

PAGE NO.

PARA-GRAPH

FIGURE NO.

TABLE NO.

IN THIS SPACE, TELL WHAT IS WRONG AND WHAT SHOULD BE DONE ABOUT IT.

TEAR ALONG PERFORATED LINE

PRINTED NAME, GRADE OR TITLE AND TELEPHONE NUMBER

SIGN HERE

THE METRIC SYSTEM AND EQUIVALENTS

WEIGHT MEASURE

1 Centimeter = 10 Millimeters = 0.01 Meters = 0.3937 Inches
 1 Meter = 100 Centimeters = 1000 Millimeters = 39.37 Inches
 1 Kilometer = 1000 Meters = 0.621 Miles

WEIGHTS

1 Gram = 0.001 Kilograms = 1000 Milligrams = 0.035 Ounces
 1 Kilogram = 1000 Grams = 2.2 lb.
 1 Metric Ton = 1000 Kilograms = 1 Megagram = 1.1 Short Tons

LIQUID MEASURE

1 Milliliter = 0.001 Liters = 0.0338 Fluid Ounces
 1 Liter = 1000 Milliliters = 33.82 Fluid Ounces

SQUARE MEASURE

1 Sq. Centimeter = 100 Sq. Millimeters = 0.155 Sq. Inches
 1 Sq. Meter = 10,000 Sq. Centimeters = 10.76 Sq. Feet
 1 Sq. Kilometer = 1,000,000 Sq. Meters = 0.386 Sq. Miles

CUBIC MEASURE

1 Cu. Centimeter = 1000 Cu. Millimeters = 0.06 Cu. Inches
 1 Cu. Meter = 1,000,000 Cu. Centimeters = 35.31 Cu. Feet

TEMPERATURE

$5/9(^{\circ}\text{F} - 32) = ^{\circ}\text{C}$
 212° Fahrenheit is equivalent to 100° Celsius
 90° Fahrenheit is equivalent to 32.2° Celsius
 32° Fahrenheit is equivalent to 0° Celsius
 $9/5^{\circ}\text{C} + 32 = ^{\circ}\text{F}$

APPROXIMATE CONVERSION FACTORS

TO CHANGE	TO	MULTIPLY BY
Inches	Centimeters	2.540
Feet	Meters	0.305
Yards	Meters	0.914
Miles	Kilometers	1.609
Square Inches	Square Centimeters	6.451
Square Feet	Square Meters	0.093
Square Yards	Square Meters	0.836
Square Miles	Square Kilometers	2.590
Acres	Square Hectometers	0.405
Cubic Feet	Cubic Meters	0.028
Cubic Yards	Cubic Meters	0.765
Fluid Ounces	Milliliters	29.573
its	Liters	0.473
arts	Liters	0.946
allons	Liters	3.785
Ounces	Grams	28.349
Pounds	Kilograms	0.454
Short Tons	Metric Tons	0.907
Pound-Feet	Newton-Meters	1.356
Pounds per Square Inch	Kilopascals	6.895
Miles per Gallon	Kilometers per Liter	0.425
Miles per Hour	Kilometers per Hour	1.609

TO CHANGE	TO	MULTIPLY BY
Centimeters	Inches	0.394
Meters	Feet	3.280
Meters	Yards	1.094
Kilometers	Miles	0.621
Square Centimeters	Square Inches	0.155
Square Meters	Square Feet	10.764
Square Meters	Square Yards	1.196
Square Kilometers	Square Miles	0.386
Square Hectometers	Acres	2.471
Cubic Meters	Cubic Feet	35.315
Cubic Meters	Cubic Yards	1.308
Milliliters	Fluid Ounces	0.034
Liters	Pints	2.113
Liters	Quarts	1.057
ers	Gallons	0.264
ms	Ounces	0.035
ograms	Pounds	2.205
Metric Tons	Short Tons	1.102
Newton-Meters	Pounds-Feet	0.738
Kilopascals	Pounds per Square Inch	0.145
ometers per Liter	Miles per Gallon	2.354
ometers per Hour	Miles per Hour	0.621

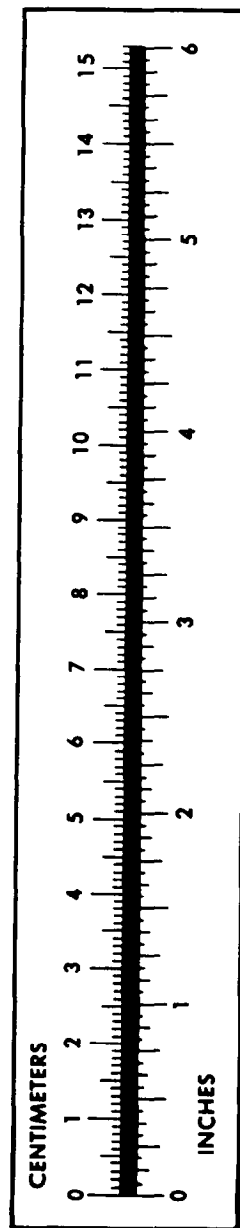

PIN: 018628-010

This fine document...

Was brought to you by me:



[Liberated Manuals -- free army and government manuals](#)

Why do I do it? I am tired of sleazy CD-ROM sellers, who take publicly available information, slap “watermarks” and other junk on it, and sell it. Those masters of search engine manipulation make sure that their sites that sell free information, come up first in search engines. They did not create it... They did not even scan it... Why should they get your money? Why are not letting you give those free manuals to your friends?

I am setting this document FREE. This document was made by the US Government and is NOT protected by Copyright. Feel free to share, republish, sell and so on.

I am not asking you for donations, fees or handouts. If you can, please provide a link to liberatedmanuals.com, so that free manuals come up first in search engines:

<A HREF=<http://www.liberatedmanuals.com/>>Free Military and Government Manuals

- Sincerely
Igor Chudov
<http://igor.chudov.com/>
- [Chicago Machinery Movers](#)