

TECHNICAL MANUAL

OPERATOR'S AND ORGANIZATIONAL MAINTENANCE MANUAL
INCLUDING REPAIR PARTS AND SPECIAL TOOLS LISTS

SEARCHLIGHT SET, INFRARED

AN/VSS-3

(NSN 5855-00-058-1293)

This copy is a reprint which includes current pages from Changes 1 and 2. The title was changed to read as shown above by Change 2.

HEADQUARTERS, DEPARTMENT OF THE ARMY
30 JANUARY 1970

WARNING

Operator and maintenance personnel should be familiar with the requirements of TB SIG 291 before attempting installation or operation of the equipment covered in this manual. Failure to follow requirements of TB SIG 291 could result in injury or DEATH.

WARNING

Do not look into the searchlight beam in either the visible or infrared mode. Even momentary viewing can produce blindness or permanent eye damage if closer than 320 meters and staring can be harmful up to 3,000 meters. Temporary flash blindness may occur at ranges exceeding 3,000 meters. Do not look into the searchlight beam with magnifying optical elements such as binoculars.

Do not direct searchlight at personnel closer than 320 meters. Blindness or permanent eye damage can be inflicted.

Do not operate the searchlight if the blower motor does not run, or turn off the vehicle power source until the blower motor stops. The blower motor cools the Xenon lamp to prevent explosion and injuries.

Do not touch the quartz envelope of the Xenon lamp with bare hands. Dirt and finger acids can erode the quartz envelope, and the lamp may explode during operation due to the weakened envelope.

Handle the spare Xenon lamp with care. This lamp is contained in a plastic holder which is necessary for installation and removal of the lamp. The container is not intended to serve as a safety container for the lamp. Avoid exposing the container with spare lamp to shock or rough treatment. This could result in explosion and injury to personnel.

Turn the searchlight power switch OFF if OVER TEMP indicator lights. Continued operation of the searchlight when high temperature is indicated can cause Xenon lamp explosion, resulting in damage to the searchlight and possible serious injury to personnel.

Make sure the vehicle power source supplying power to the searchlight set is turned off before performing the interunit cabling procedure.

Always disconnect the searchlight power cable before opening the searchlight case. When the power cable is connected to the searchlight, 28 volts dc is present between the housing and internal components of the searchlight. Any contact with the case and internal components can produce electrical shock and injury to personnel.

Installation of the searchlight is a two-person operation. Failure to use two persons to install the searchlight could result in dropping or severe jarring of the searchlight,

with subsequent damage to the equipment, or possible serious injury or DEATH to personnel.

installation of the control box is a two-person operation. Failure to use two persons to install the control box could result in serious injury to personnel.

HIGH VOLTAGES

Dangerous voltages which can cause DEATH or serious injury are present in the searchlight set at the following locations:

30,000 volts is present on Xenon lamp electrode and igniter unit terminals during lamp ignition.

3,000 volts is present on starting coil and igniter during lamp ignition.

120 volts dc is present on starting coil in the searchlight case and on capacitor bank in the control box during lamp ignition.

TECHNICAL MANUAL }
No. 11-5855-217-12 }

HEADQUARTERS
DEPARTMENT OF THE ARMY
WASHINGTON, D. C., 30 January 1970

**Operator's And Organizational
Maintenance Manual**
Including Repair Parts and Special Tools Lists
SEARCHLIGHT SET, INFRARED AN/VSS-3
(NSN 5855-00-058-1293)

	Paragraph	Page
CHAPTER 1. INTRODUCTION		
Section I. General	1-1-1-3	1-1
II. Description and data	1-4-1-10	1-1-1-8
III. Basic principles	1-11, 1-12	1-10, 1-11
CHAPTER 2. INSTALLATION		
Section I. Service upon receipt of Searchlight Set, Infrared AN/VSS-3	2-1-2-3	2-1
II. Installation procedures	2-4,2-5	2-4
CHAPTER 3. OPERATING INSTRUCTIONS		
Section I. Operator's controls and indicators	3-1, 3-2	3-1
II. Operation under usual conditions	3-3-3-9	3-2, 3-3
III. Operation under unusual conditions	3-10-3-14	3-3, 3-4
CHAPTER 4. OPERATOR MAINTENANCE		
Section I. General	4-1, 4-2	4-1
II. Operator preventive maintenance	4-3-4-9	4-1-4-3
CHAPTER 5. ORGANIZATIONAL MAINTENANCE		
Section I. General	5-1, 5-2	5-1
II. Organizational preventive maintenance	5-3-5-7	5-1, 5-2
III. Organizational troubleshooting and repairs	5-8, 5-9	5-2, 5-3
IV. Repairs	5-10-5-19	5-4-5-9
CHAPTER 6. SHIPMENT, LIMITED STORAGE, AND DEMOLITION TO PREVENT ENEMY USE		
Section I. Shipment and limited storage	6-1, 6-2	6-1
II. Demolition of material to prevent enemy use	6-3-6-6	6-1, 6-2
APPENDIX A. REFERENCES		A-1
B. BASIC ISSUE ITEMS		B-1
C. MAINTENANCE ALLOCATION		C-1
D. ORGANIZATIONAL REPAIR PARTS AND SPECIAL TOOLS LIST		D-1
INDEX		I-1

* This manual supersedes TM 11-5855-217-12, 28 October 1968.

LIST OF ILLUSTRATIONS

<i>Figure No.</i>	<i>Title</i>	<i>Page</i>
1-1	Searchlight Set, Infrared AN/VSS-3	1-2
1-2	Searchlight, three-quarter, left-side view	1-4
1-3	Searchlight, three-quarter right-side view	1-5
1-4	Searchlight, heat exchanger removed	1-6
1-5	Searchlight support assembly, left front view	1-7
1-6	Heat exchanger, inside view	1-8
1-7	Control Box, front view	1-9
1-8	Remote control box, front view	1-9
1-9	Searchlight with searchlight mount, three-quarter, right lower view	1-10
1-10	Searchlight modes of operation	1-11
2-1,	Typical packaging of the searchlight set (part 1 of 2)	2-2
2-1,	Typical packaging of the searchlight set (part 2 of 2)	2-3
5-1	Searchlight, window replacement, exploded view	5-5
5-2	Searchlight, Xenon lamp replacement, exploded view	5-6
5-3	Replacement of indicator lamps	5-8

CHAPTER 1 INTRODUCTION

Section I. GENERAL

1-1. Scope

a. This manual describes Searchlight Set, Infrared AN/VSS-3 and covers its installation and operation, and operator and organizational maintenance. It includes operation under usual and unusual conditions, cleaning and inspection of the equipment, and replacement of parts available to operator and organizational maintenance personnel.

b. Appendix A contains a list of publications applicable to the equipment, appendix B contains the basic issue items list, appendix C contains the maintenance allocation chart, and appendix D contains the organizational repair parts list.

NOTE

Appendix B is current as of 6 June 1973. Appendixes C and D are current as of 25 January 1970.

1-2. Indexes of Publications

a. *DA Pam 310-4.* Refer to the latest issue of DA Pam 310-4 to determine whether there are new editions, changes, or additional publications pertaining to the equipment.

b. *DA Pam 310-7.* Refer to DA Pam 310-7 to determine whether there are modification work orders (MWO'S) pertaining to the equipment.

1-3. Forms and Records

a. *Reports of Maintenance and Unsatisfactory Equipment.* Maintenance forms, records, and reports which are to be used by maintenance personnel at all maintenance levels are listed in and prescribed by TM 38-750.

b. *Report of Packaging and Handling Deficiencies.* Fill out and forward DD Form 6 (Packaging Improvement Report) as prescribed in AR 700-58 /NAVSUPINST 4030.29/AFR 71-13/MCO P4030.29A, and DSAR 4145.8.

c. *Discrepancy in Shipment Report (DISREP) (SF 361).* Fill out and forward Discrepancy in Shipment Report (DISREP) (SF 361) as prescribed in AR 55-38/NAVSUPINST 4610.33 A/AFR 75-18/MCO P4610.19B, and DSAR 4500.15.

1-3.1. Reporting of Errors

Reporting of errors, omissions, and recommendations for improving this publication by the individual user is encouraged. Reports should be submitted on DA Form 2028 (Recommended Changes to Publications and Blank Forms) and forwarded direct to Commander, US Army Electronics Command, ATTN: DRSEL-MA-Q, Fort Monmouth, New Jersey 07703.

1-3.2. Reporting Equipment Improvement Recommendations (EIR)

EIR's will be prepared using DA Form 2407 (Maintenance Request). Instructions for preparing EIR's are provided in TM 38-750, The Army Maintenance Management System. EIR's should be mailed direct to Commander, US Army Electronics Command, ATTN: DRSEL-MA-Q, Fort Monmouth, New Jersey 07703. A reply will be furnished direct to you.

1-3.3. Administrative Storage

Administrative storage of equipment issued to and used by Army activities shall be in accordance with TM 740-90-1.

Section II. DESCRIPTION AND DATA

1-4. Purpose and Use

a. Searchlight Set, Infrared AN/VSS-3 (fig. 1-1) is a weather-resistant, watertight, general-purpose, tank-mounted searchlight which provides a compact (focused) or spread (defocused) beam of high-intensity visible or infrared (IR) light. It is used to provide illumination of battlefield areas, jobsites, and rear areas.

b. Searchlight Set, Infrared AN/VSS-3 is provided with hardware for mounting on tanks. Electrical power for operation is obtained from the vehicle power source of 22 to 28 volts direct current (dc), 1.6 kilowatt (kw) or greater capacity.

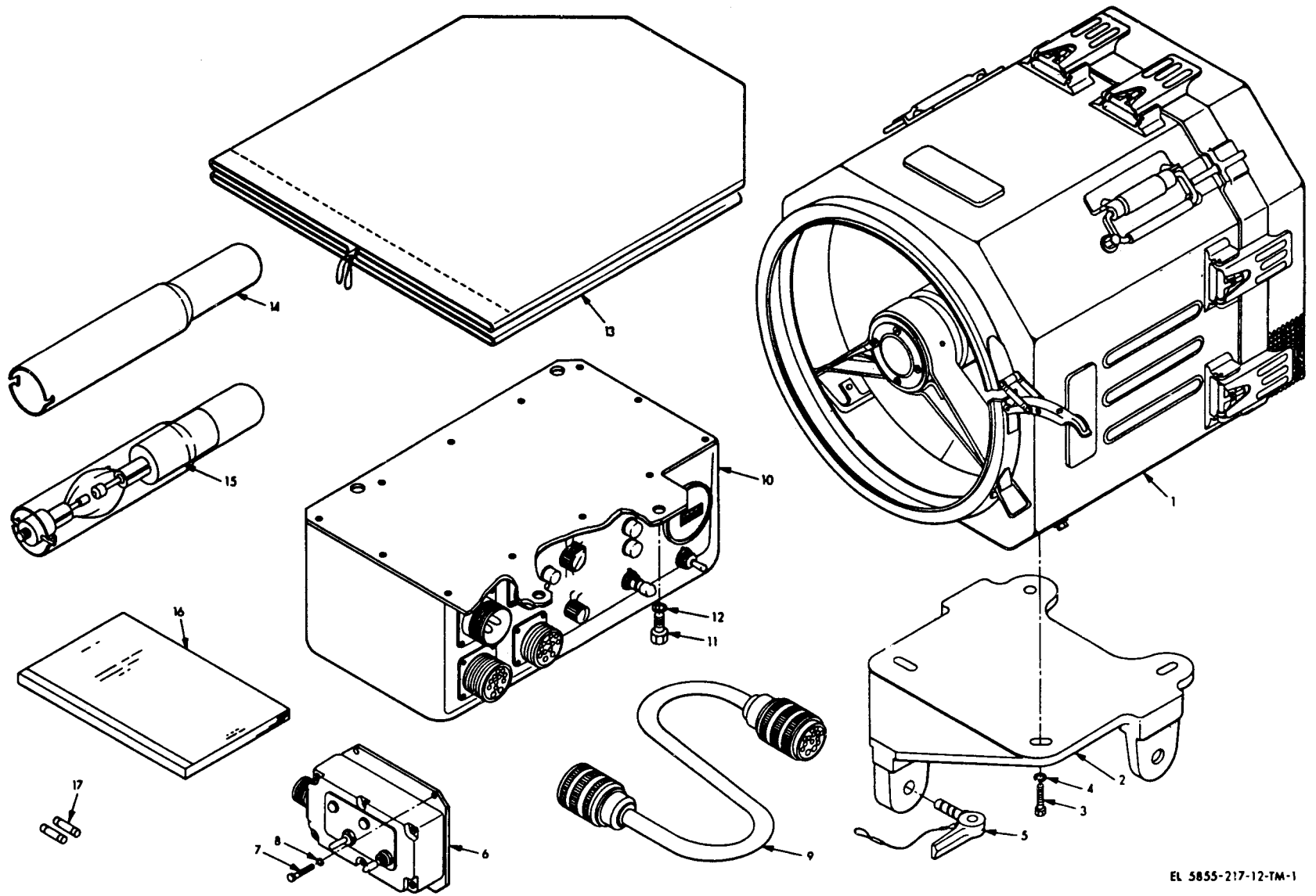

Figure 1-1. Searchlight Set, Infrared AN/VSS-3.

- 1 Searchlight, Infrared MX-8272/VSS-3 (1)
- 2 Searchlight mount (MP2)
- 3 Mounting screw (H7-4)
- 4 Flat washer (H6-4)
- 5 Mounting pin (H1-3)
- 6 Control, Searchlight Set C-7906/VSS-3 (3)
- 7 Mounting screw (H2-4)
- 8 Lockwasher (H3-4)
- 9 Cable Assembly, Power, Electrical CX-11893/VSS-3 (4W)
- 10 Control, Searchlight Set C-7905/VSS-3 (2)
- 11 Mounting screw (H4-4)
- 12 Lockwasher (H5-4)
- 13 Searchlight cover (MP1)
- 14 Lampholder (MP2)
- 15 Lamp and holder assembly (A1)
- 16 Technical Manual 11-5855-217-12
- 17 Fuses (installed in spare fuse holders inside item 1)

Figure 1-1. Searchlight Set, Infrared AN/VSS-3.-Continued

1-5. Tabulated Data

<p>Type of light Visible or infrared.</p> <p>Type of lamp Xenon, short arc, 1.0 kilowatt.</p> <p>Peak output: candlepower 50 million (minimum).</p> <p>Beam width: Compact 1.0° (minimum). Spread 7.0°±.5°. Variable 1.0° to 7.0°.</p> <p>Input power require- ment: Voltage 22 to 28 volts dc. Current 52 amperes maximum (75° to 115°F, 24° to 46°c); 58 amperes maxi- mum (-65° to 75°F, -54° to 24°c).</p>	<p>Power 1.6 kilowatt (minimum).</p> <p>Mode of operation: Visible light Compact, spread, or variable beam width. Infrared light Compact, spread, or variable beam width.</p> <p>Cooling system Air-to-air heat ex- changer using integral intake exhaust blower.</p> <p>Reflective system Metal parabolic mirror.</p> <p>Focus-defocus method Motor driven.</p> <p>Searchlight control Provided by control box and remote control box.</p>
--	---

1-6. Items Comprising an Operable Equipment

FSN	Item	Quantity	Height (in)	Depth (in)	Width (in)	Weight (lb)
5855-058-1293	Searchlight Set, Infrared AN/VSS-3 Consisting of:	1				
5855-135-0156	Searchlight, Infrared MX-8272/VSS-3	1	15	18 3/4	15	62
5855-135-0162	Searchlight, mount	1	3 5/8	11 3/4	10 1/2	43/4
5305-716-8186	Mounting screw	4	1 1/8		1 1/2	
5310-767-9425	Flat washer	4			1	
5340-143-0356	Mounting pin	3	3		3/8	
5855-135-0155	Control, Searchlight Set C-7905/VSS-3	1	6 1/8	11 3/8	16	23 1/2
5305-269-2803	Mounting screw	4	1		3/8	
5310-061-1258	Lockwasher	4			1/2	
5855-135-0154	Control, Searchlight Set C-7906/VSS-3	1	3	4 5/8	5 5/8	11/2
5305-983-6651	Mounting screw	4	1/2			
5310-721-7809	Lockwasher	4			3/8	
5995-135-0081	Cable Assembly, Power, Electrical CX-11893/VSS-3	1		3 ft lg		23/4

NOTE

Running spares that accompany Searchlight Set, Infrared AN/VSS-3 are listed in appendix B. A power source of 22 to 28 volts dc, 58 amperes (maximum) is not supplied with or is part of the AN/VSS-3, but is needed for equipment operation.

1-7. Common Names

A list of common name assignments for components of the searchlight set is given below.

<i>Common name</i>	<i>Nomenclature</i>
Canvas cover	Searchlight cover
Control box	Control, Searchlight Set C-7905/VSS-3.
Power cable	Cable Assembly, Power, Electrical CX-11893/VSS-3.
Remote control box	Control, Searchlight Set C-7906/VSS-3.
Searchlight	Searchlight, Infrared MX-8272/VSS-3.
Searchlight set	Searchlight Set, Infrared AN/VSS-3.

1-8. Description of Equipment

CAUTION

The components of this searchlight are not compatible with any other equipment except that which is covered in this manual. If an AN/VSS-3 searchlight subassembly is connected to an AN/VSS-3A control box, the booster-starter module will burn out. If an AN/VSS-3A searchlight subassembly is connected to an AN/VSS-3 control box, the searchlight will not operate but no damage will occur.

Searchlight Set, Infrared AN/VSS-3 (fig. 1-1) consists of four major components (with their attaching parts), two accessories (with attaching parts), and four running spares. The four components are the searchlight with the searchlight mount with four mounting screws and flatwashers and three mounting pins (mounting hardware), the control box with four mounting screws and lockwashers (mounting hardware), the remote control box with four mounting screws and lockwashers (mounting hardware), and the power cable. The two accessories consist of the canvas cover and the technical manual. The lamp and holder assembly, the spare lampholder, and two fuses comprise the running spares. A suitable power source (not shown) is also required for operation.

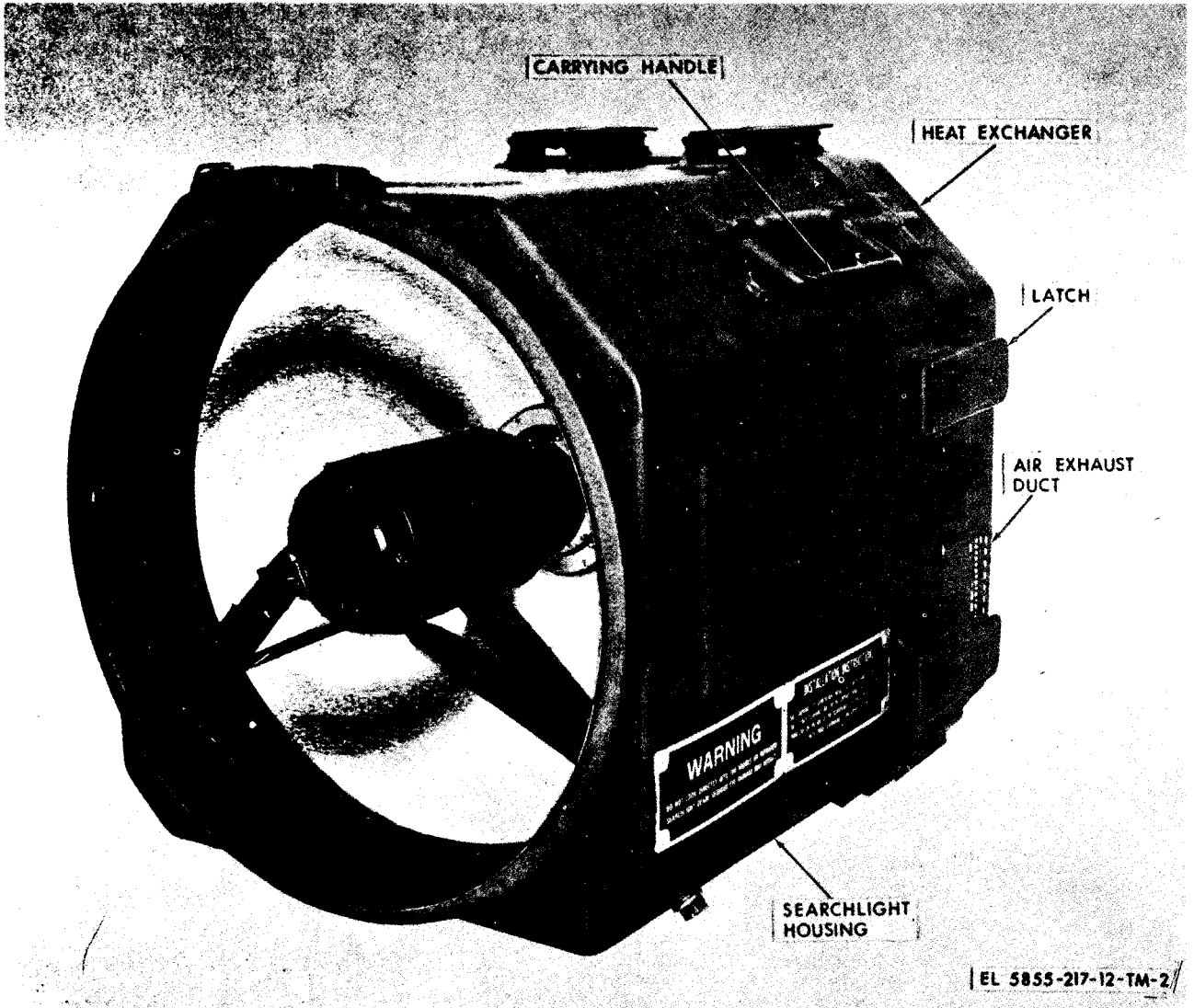

Figure 1-2. Searchlight, three-quarter, left-side view.

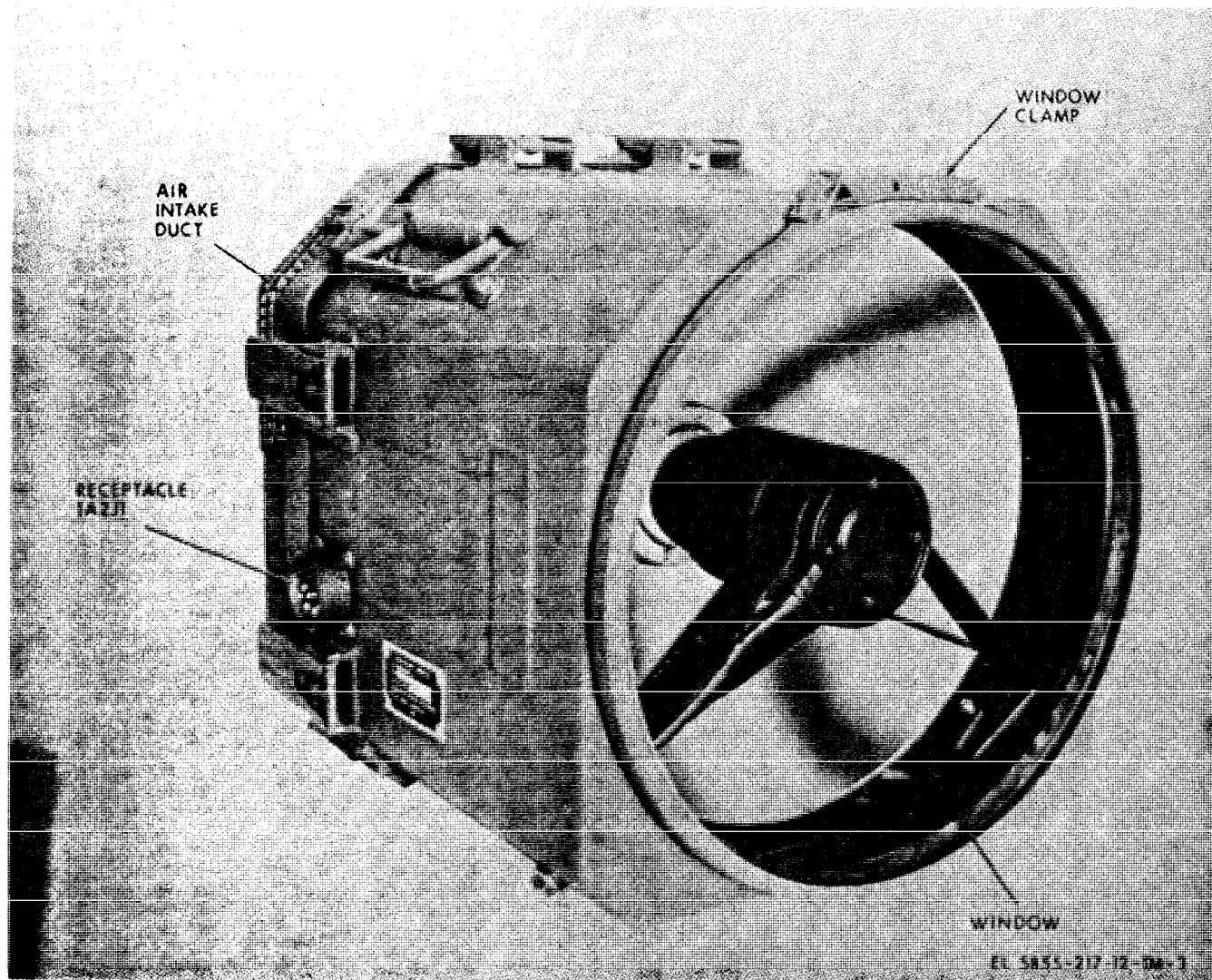

Figure 1-3. Searchlight, three-quarter right-side view.

a. Searchlight. This unit contains the greater part of the searchlight set components and protects the internal components from physical damage and exposure to dust and moisture. The searchlight consists of the main frame assembly, searchlight housing, heat exchanger, window, and window clamp. The searchlight is attached to the searchlight mount by means of mounting hardware.

(1) *Searchlight support assembly* (figs. 1-4 and 1-5). This assembly consists of the main frame, reflector, xenon lamp, IR filter, diode CR1, igniter, booster, terminal board TB1, IR drive motor, focus drive motor, fuses F1 and F2, spare fuses and shock mounts. Low voltage (28 volts

dc) from the vehicle power source is converted to a high voltage (3 kilovolts (kv) from booster and 35 kv from igniter), for ignition of the xenon lamp. After the lamp is ignited, the 28 volts dc is used to maintain lamp illumination. The light produced by the xenon lamp is concentrated and shaped by the reflector. Mechanical controls are used to position the IR filter over the xenon lamp for IR illumination.

(2) *Searchlight housing* (figs. 1-2 and 1-4). The searchlight housing is a pressed aluminum shell fitted with carrying handles, latches, and an electrical receptacle. The housing contains the searchlight support assembly, which is attached to it by shock mounts.

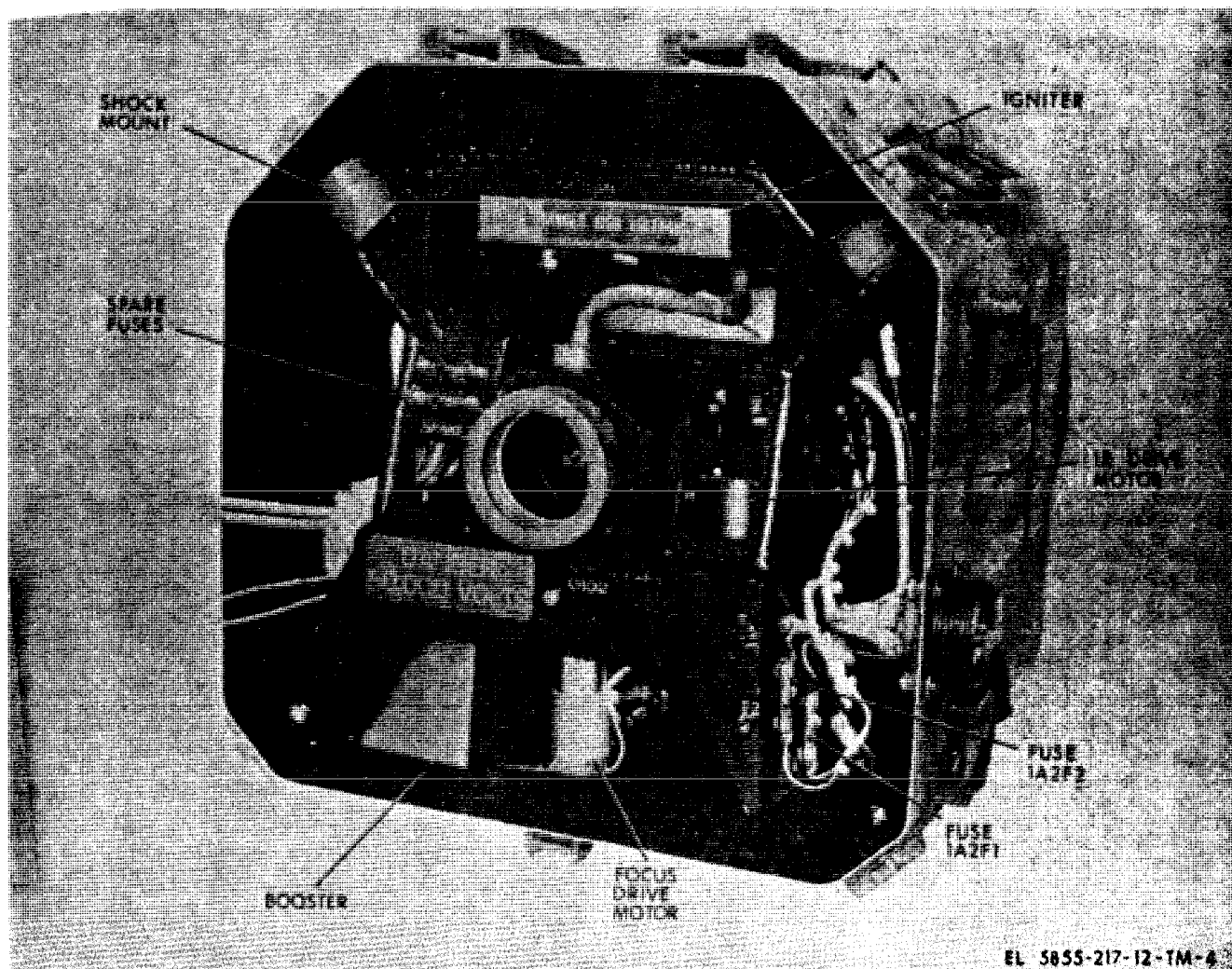

Figure 1-4. Searchlight, heat exchanger removed.

(3) *Heat exchanger* (figs. 1-2, 1-3, and 1-6). The heat exchanger is attached to the rear of the searchlight housing and electrically connected to the main frame assembly. This unit contains the blower motor, with intake and exhaust fans, ballast resistor, and the rear cover to which air ducts and cooling fins are attached.

(4) *Window and window clamp* (figs. 1-3 and 5-1). The window is sealed and attached to the searchlight housing by the window seal and window (grooved) clamp. The window provides protection against dust and moisture.

(5) *Searchlight mount* (fig. 1-9). The searchlight mount is used to mount the searchlight

to the vehicle support (not shown). The two supports are held together by three mounting pins. The vehicle support is fastened to the tank and the searchlight mount is attached to the searchlight by four capscrews and flat washers. The searchlight mount provides rigidity for searchlight mounting and allows the searchlight to be easily removed for tactical situations or maintenance.

b. Control Box (fig. 1-7). This unit contains the necessary switches and indicators for operating, monitoring operation, and troubleshooting the searchlight. It is mounted within the vehicle and consists of a housing and a mounting plate.

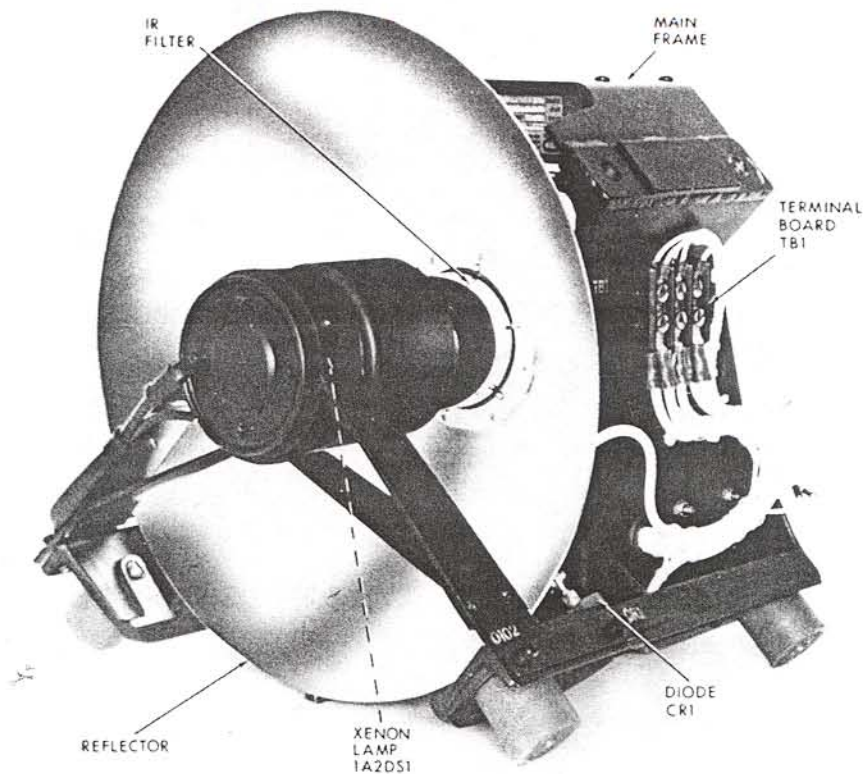

EL 5855-217-12-TM-5

Figure 1-5. Searchlight support assembly, left front view.

(1) The housing contains the control, power, and beam switches used to control searchlight operation, the CIRCUIT TEST switch and indicator used for troubleshooting, and the OVER TEMP, LAMP ON, and ELAPSED TIME indicators used to monitor searchlight operation. Also, the housing contains receptacles for power and intercomponent connections.

(2) The mounting plate attached to the housing is used to mount the control box within the vehicle.

c. Remote Control Box (fig. 1-8). This unit contains the necessary switches and indicators for operating and monitoring the operation of the searchlight from the remote position. It is

mounted within the tank and consists of a housing and a mounting plate.

(1) The housing contains the control, power, and beam switches used to control the operation of the searchlight. Also, the housing contains the OVER TEMP and LAMP ON indicators and a receptacle for connection to the control box.

(2) The mounting plate attached to the panel housing is used to mount the remote control box within the tank.

d. Power Cable (fig. 1-1). This cable is connected between the searchlight and the vehicle. The cable is approximately 36 inches long and is waterproof.

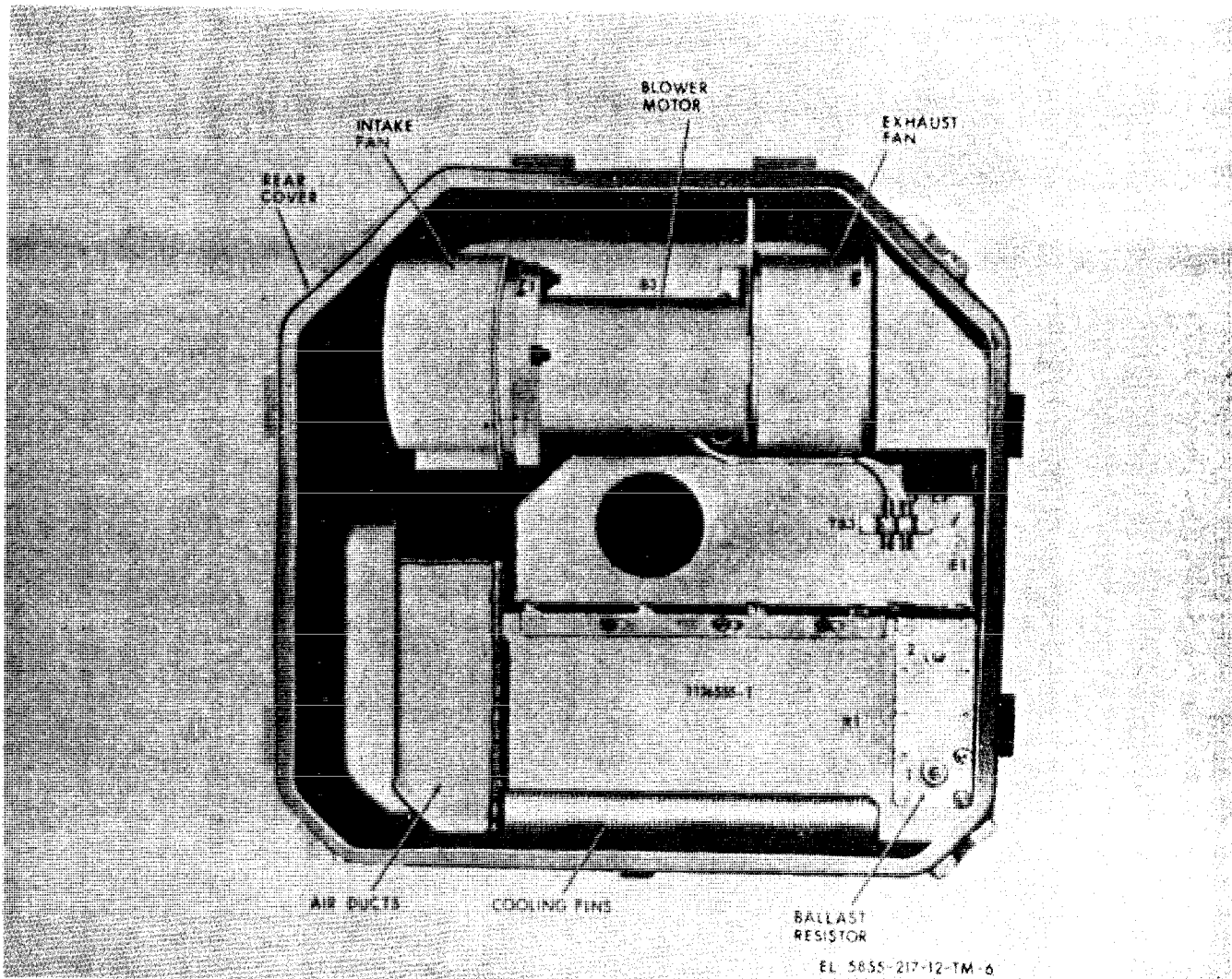

Figure 1-6. Heat exchanger, inside view.

1-9. Description of Minor Components
(fig. 1-1)

a. Accessories included in the searchlight set are the technical manual and the searchlight cover. The searchlight cover is a canvas cover used to protect the searchlight when the equipment is not in operation. The portion which covers the window contains a stiffener to protect the glass.

b. Running spares consist of a lamp and holder assembly and a lampholder which are used by organizational maintenance to replace the xenon lamp. Two spare cartridge fuses are also included.

(1) *Lamp and holder assembly.* A spare xenon lamp is mounted in a lampholder. This lampholder is used as an installation tool and also as a protective cover for the xenon lamp.

(2) *Lampholder.* The lampholder is used for removal of the xenon lamp when it is inoperative.

1-10. Additional Equipment Required

An outside power source is required to operate the searchlight set. The searchlight operates from 22 to 28 volts dc with a maximum current consumption of 58 amperes. This power source is connected to a receptacle on the front of the control box.

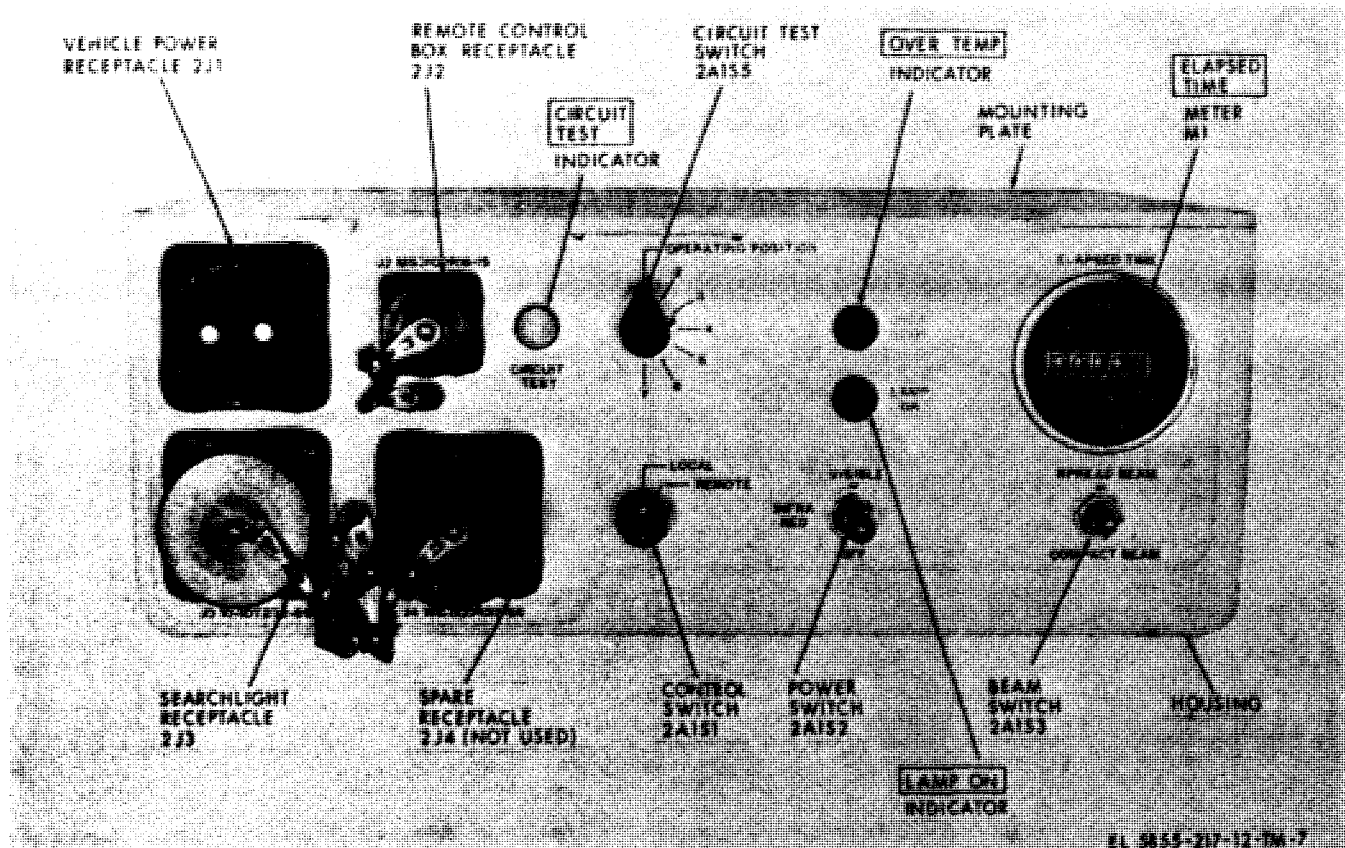

Figure 1-7. Control box, front view.

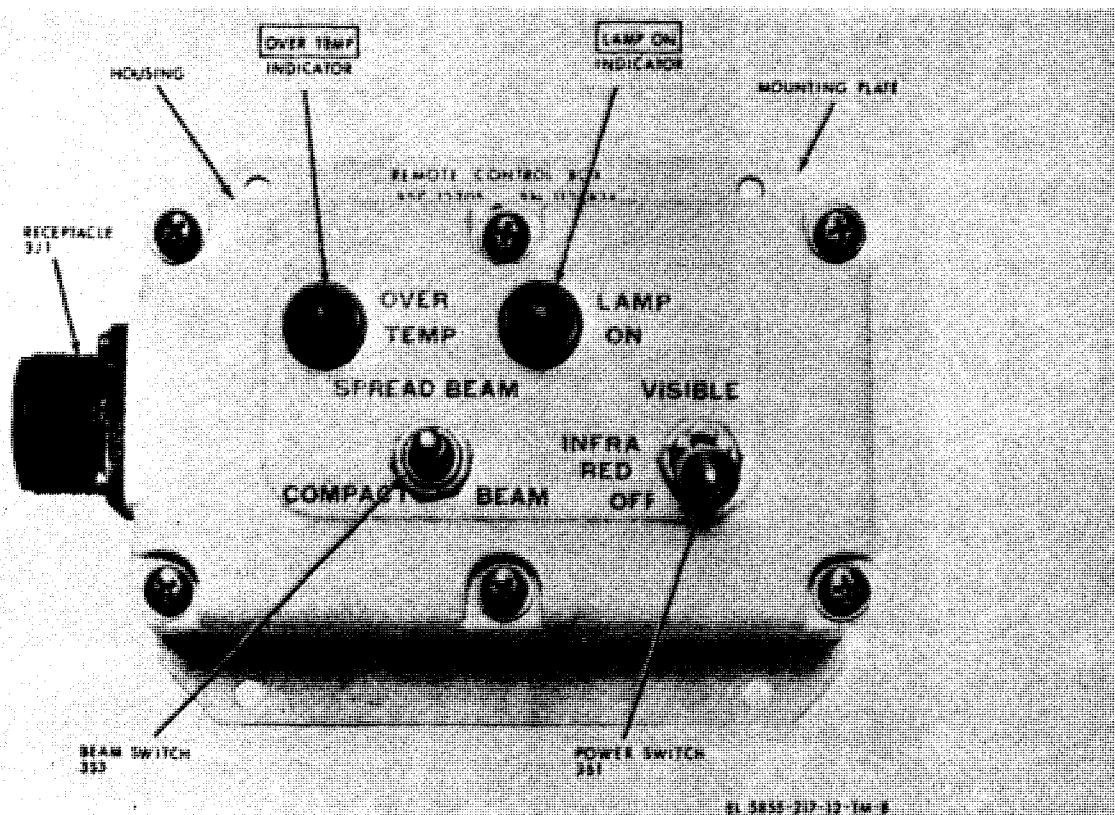

Figure 1-8. Remote control box, front view.

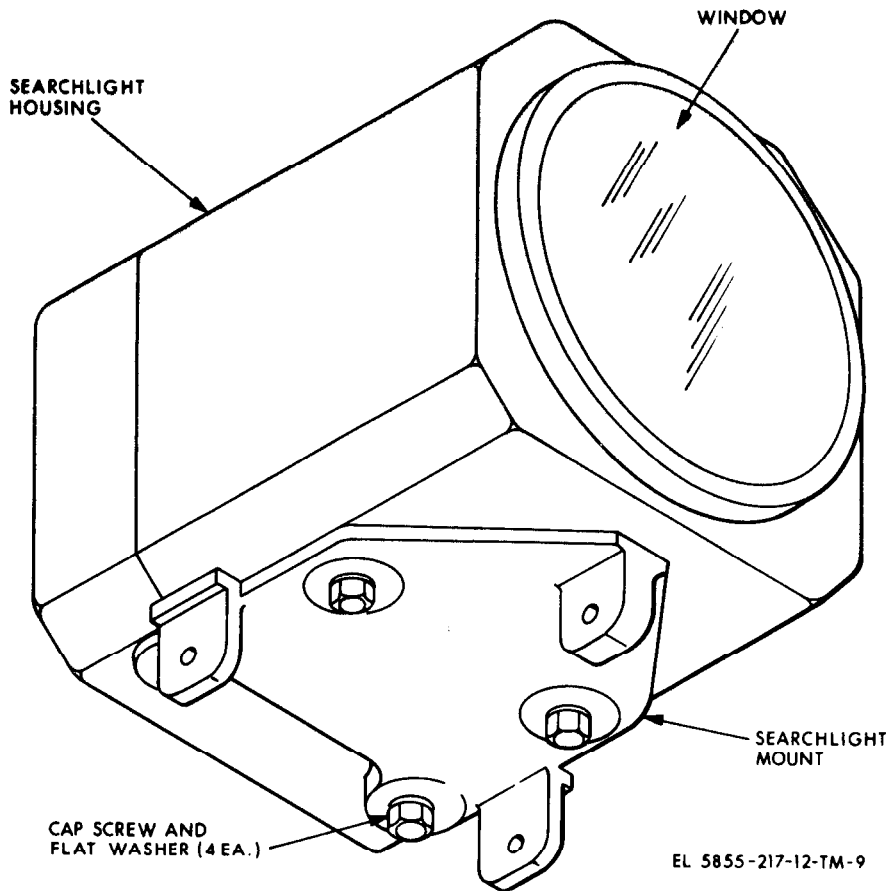

Figure 1-9. Searchlight with searchlight mount, three-quarter, right lower view.

Section III. BASIC PRINCIPLES

1-11. General

The operation of the searchlight is dependent on the performance of two major functions. The first function is the ignition and continual illumination of the xenon lamp, while the second is the control of the searchlight modes of operation.

a. Ignition and Continual Illumination of Xenon Lamp. Ignition of the xenon lamp is accomplished by the lamp igniter, booster, and capacitor bank. At power turn-on, the booster begins to charge a capacitor in the igniter located in the searchlight and the capacitor bank located in the control box. When the igniter capacitor charge reaches 3,000 volts, the igniter applies 40,000 volts across the

lamp through a transformer. The gas in the lamp ionizes, and the capacitor bank discharges through the xenon lamp, supplying a high current surge to complete lamp ignition (arcing). After xenon lamp ignition, continual illumination is achieved by maintaining a nearly constant dc voltage across the xenon lamp through a ballast resistor,

b. Searchlight Modes of Operation. (fig. 1-10). The searchlight has two basic modes of operation: visible or infrared (IR), either of which can be operated in a compact (focused) beam, spread (defocused) beam, or a variable beam of light. The power switch on the control box is used to select visible or IR mode, and the beam switch controls the beam width.

1-12. Equipment Function

a. General. When the 28-volt dc source is connected to the searchlight set, dc power is distributed but is not available to the searchlight until the power switch is placed in either the INFRARED or VISIBLE position. When the power switch is at INFRARED or VISIBLE, the lamp igniter operates, causing the xenon lamp to ignite. After ignition, the 28-volt dc operating circuit is applied to the xenon lamp to sustain the arc and provide continual illumination. The 28-volt dc circuit is also used to operate the IR filter and focus drive motors and provide power to the blower motor in the air-to-air heat exchanger.

b. Infrared Filter. The static position (power switch set to OFF) of the IR filter is that it completely surrounds the xenon lamp (D, E, and F, fig. 1-10). Therefore, when the power switch is at INFRARED, the IR filter does not change posi-

tion, and only infrared light is projected from the searchlight. When the power switch is at VISIBLE, the IR filter drive motor retracts the IR filter away from the xenon lamp (A, B, and C, fig. 1-10), allowing visible light to be projected from the searchlight.

c. Reflector. The reflector collects the light emitted by the xenon lamp and directs it into a beam. The focus drive motor is used to change the shape of the reflector and deflect a portion of the light beam upward. The reflector does not move but is held rigidly to its mount while being slightly deformed by the deflector mechanism.

d. Focus Drive Motor. The focus drive motor is used to change the shape of the reflector assembly and the position of the xenon lamp, thereby changing the beam width. The normal unchanged configuration of the reflector assembly with the xenon lamp located at its focal point will cause the

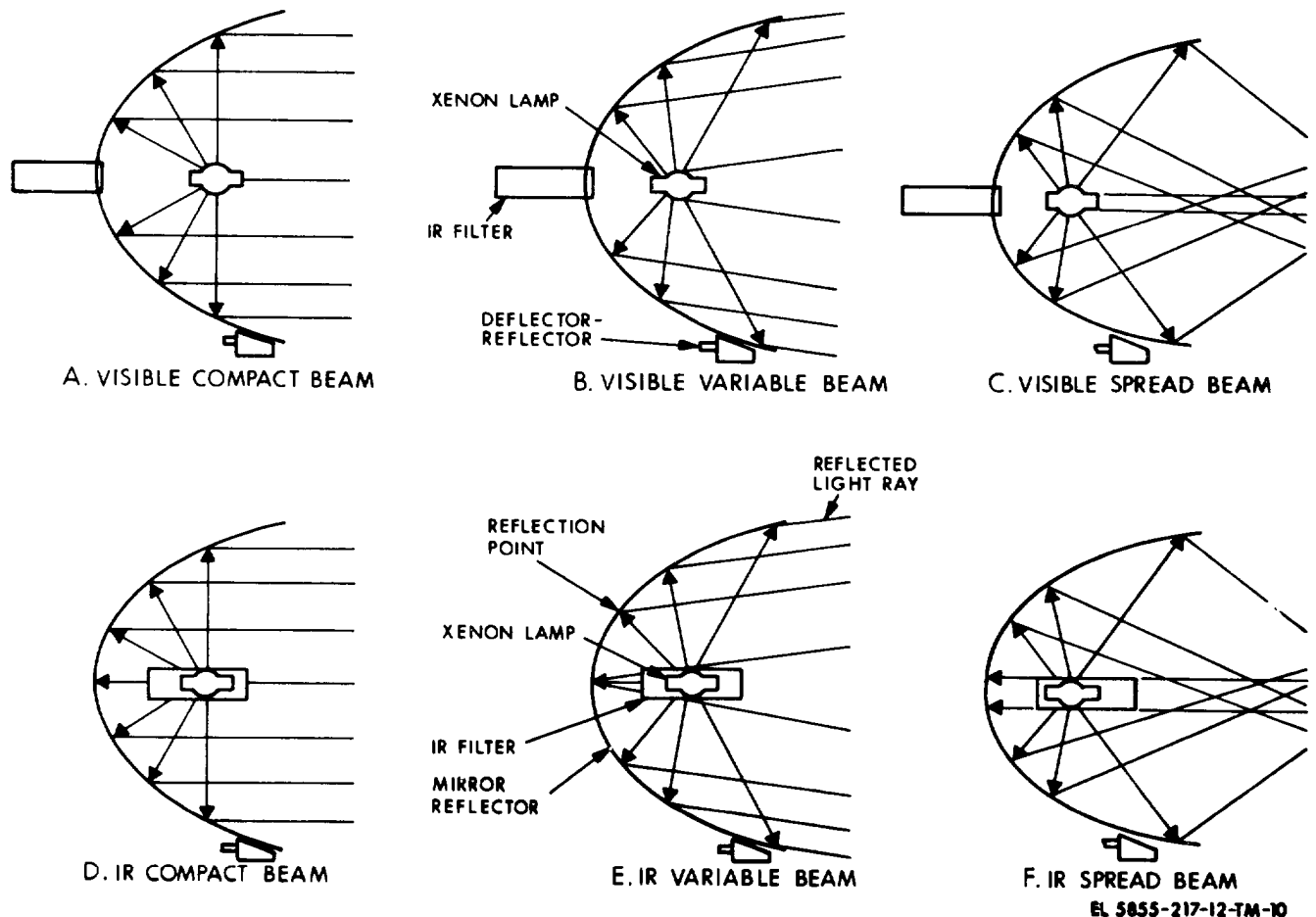

Figure 1-10. Searchlight modes of operation.

light beam to be compact (A and D, fig. 1-10). When the beam switch is placed in the SPREAD BEAM position, the focus drive motor moves the xenon lamp away from its focal point toward the reflector and deforms the reflection, producing a defocused or spread beam. Stopping the focus drive motor anytime before the maximum beam spread is achieved, produces a variable beam (B and E, fig. 1-10). Allowing the focus drive motor to achieve maximum beam spread produces a spread beam (C and F, fig. 1-10).

e. Heat Exchanger. An air-to-air heat exchanger with a centrifugal fan provides cooling of the xenon lamp and IR filter assemblies. The fan operates when the power switch is at INFRARED or VISIBLE. When the power switch is at OFF,

the fan will continue to operate until the search-light components have cooled to below 125° F.

f. Igniter. When the power switch is at INFRARED or VISIBLE, 3,000 volts is applied to the igniter. The igniter steps up the voltage to a nominal 40 kilovolts and applies this voltage to the xenon lamp. After lamp ignition, the igniter remains inoperative until lamp ignition is again required.

g. Booster. When the power switch is at INFRARED or VISIBLE, the booster applies 3,000 volts to the igniter and 120 volts to the capacitor bank in the control box. Also, the booster supplies 10 volts to the vehicle power source to insure ignition of the lamp. After lamp ignition, the booster becomes inoperative.

CHAPTER 2 INSTALLATION

Section I. SERVICE UPON RECEIPT OF SEARCHLIGHT SET, INFRARED AN/VSS-3

2-1. General

(fig. 2-1)

a. When packed for shipment, the components of the searchlight set are packed in a wooden shipping

box. The smaller components are packed in a carton which is placed within the shipping box.

b. Dimensions, weight, and contents of the shipping box and carton are listed below.

<i>Package</i>	<i>Dimensions (in.)</i>	<i>Unit weight (lb)</i>	<i>Contents</i>
Shipping box	33 1/4 lg x 25 w x 21 h	130	Complete searchlight set, including carton
Carton	22 lg x 19 1/2 w x 9 5/8 h	37	Searchlight mount, control box, remote control box, power cable, lamp-holder, lamp and holder assembly, technical manual, and paper bag
Paper bag		1.2	4 socket-head screws 4 lockwashers 4 hexagonal head screws 4 washers 4 flat washers 4 hexagonal head screws 3 mounting pins

2-2. Unpacking

(fig. 2-1)

NOTE

Perform all the procedures listed below, in the order given, when unpacking equipment from shipping box.

a. Pry open and remove the lid of the shipping box (fig. 2-1).

b. Remove the carton from the shipping box.

NOTE

Removing the searchlight from the shipping box requires two men.

c. Carefully remove the searchlight from the shipping box.

d. Remove the wrapping material from each packaged item.

2-3. Checking Unpacked Equipment

a. Inspect the equipment for any damage that may have occurred during shipment. If the equipment

has been damaged, report the damage on DD Form 6 (para 1-3).

b. See that the equipment is complete as listed on the packing slip. If a packing slip is not available, check the equipment against the basic issue items list (appx B) and paragraph 1-6. Report all discrepancies in accordance with TM 38-750. Shortage of a minor assembly or part that does not affect proper functioning of equipment will not prevent use of the equipment.

c. If equipment has been used or reconditioned, see whether it has been changed by a modification work order (MWO). If equipment has been modified, the MWO number will appear on front panel near nomenclature plate. Check to see whether the MWO number, if any, and appropriate notations concerning modification have been entered in equipment manual.

NOTE

Current MWO'S applicable to the equipment are listed in DA Pam 310-7.

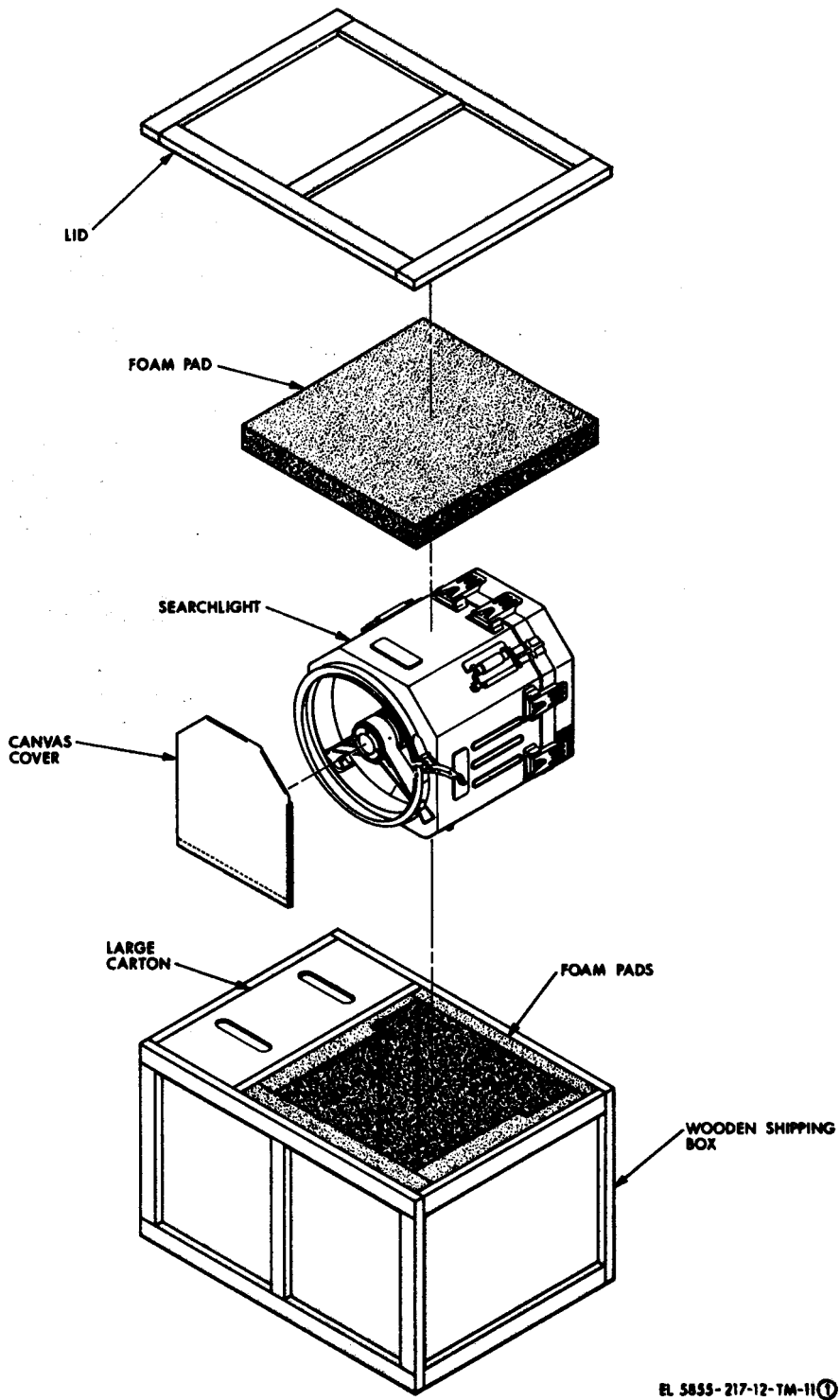

EL 5855-217-12-TM-11①

Figure 8-1①. Typical packaging of the searchlight set (part 1 of 2).

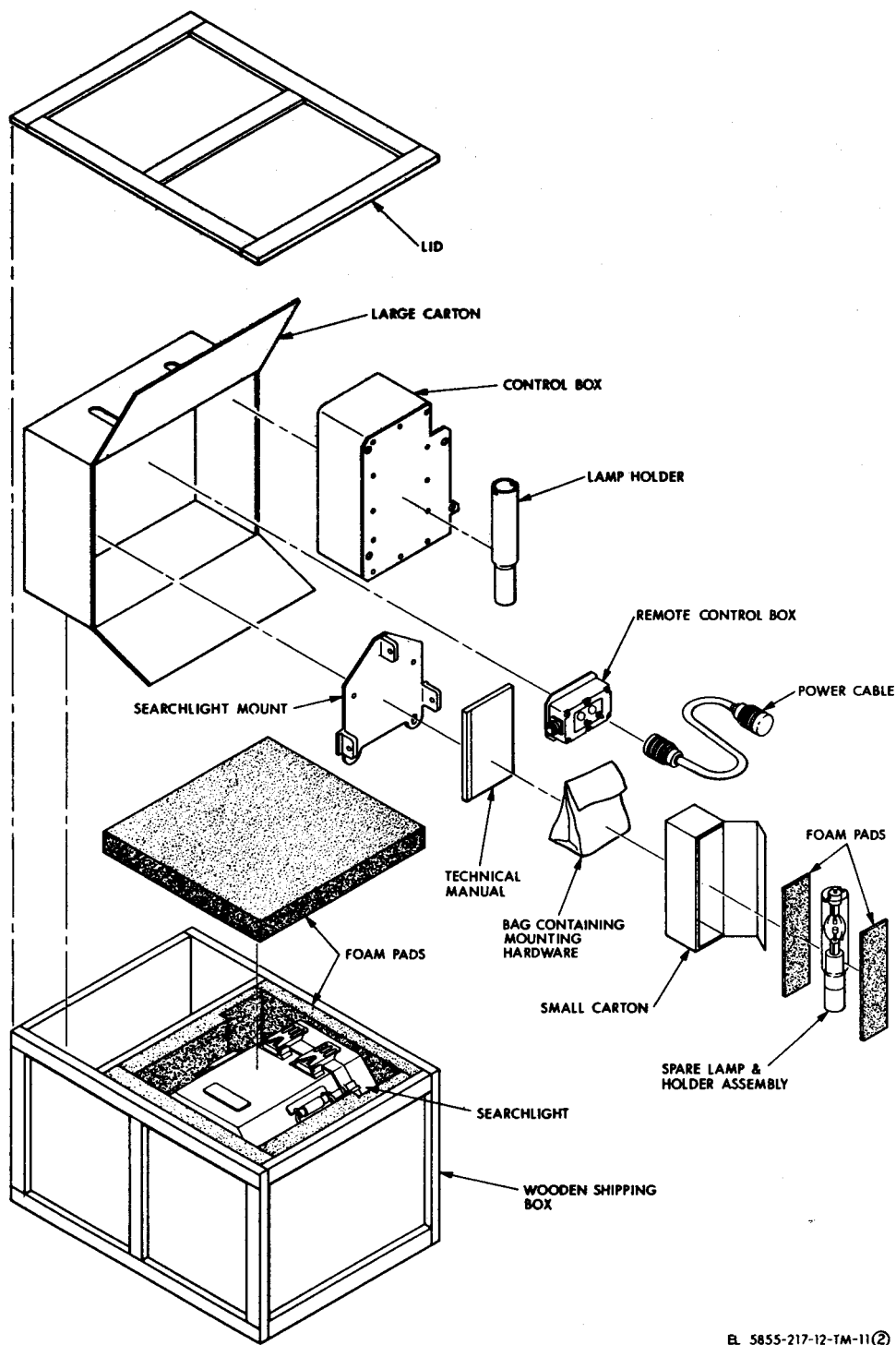

EL 5855-217-12-TM-11(2)

Figure 2-1(2). Typical packaging of the searchlight set (part 2 of 2).

Section II. INSTALLATION PROCEDURES

2-4. General

Installation of the searchlight set will not be performed by U.S. Army Electronics Command maintenance personnel. The searchlight set will be fielded, installed on the vehicle.

2-5. Servicing

Perform the operator's preventive maintenance checks and services (para 4-5). When the tests are completed, report the equipment ready for operation.

CHAPTER 3 OPERATING INSTRUCTIONS

Section I. OPERATOR'S CONTROLS AND INDICATORS

WARNING

Before operating this equipment, make sure that all requirements of TB SIG 291 are met. Injury or DEATH could result from improper or careless operation.

3-1. Searchlight Control

(figs. 1-7 and 1-8)

<i>Control</i>	<i>Function</i>
COMPACT BEAM-SPREAD BEAM (Beam switch)	COMPACT BEAM (down) position-searchlight produces a narrow light beam. SPREAD BEAM (up) position (spring-loaded), spreads beam from 1.0° compact to full spread at 7.0°. Approximately 2 seconds is required for full beam expansion. To hold beam at any width between two extremes, release beam switch and allow it to return to center position. <i>Note.</i> Center position is off position for focus motor. Holds beam width fixed while beam switch is at SPREAD BEAM.
OFF-INFRARED-VISIBLE (power switch)	OFF (down) position-turns off power to set and returns searchlight to infrared mode. INFRARED (middle) position-places searchlight in infrared operating mode. visible (up) position-places searchlight in visible operating mode.
CIRCUIT TEST switch	OPERATING POSITION-normal position for operating searchlight. Position 2-tests for input voltage level at 22 volts dc minimum. Position 3-tests ballast resistor for continuity. Position 4-tests switching diode CR1 for continuity. Position 5-tests for application of 22 to 28 volts dc to blower motor. Position 6-tests lamphouse connector for continuity. Position 7-tests input voltage and power relay K1 operation.
LOCAL-REMOTE (control switch)	LOCAL position-switches control of searchlight to control box. REMOTE position-switches control of searchlight to remote control box.

3-2. Searchlight Indicators

(figs. 1-7 and 1-8)

<i>Indicator</i>	<i>Function</i>
OVER TEMP indicator	Indicates when searchlight is overheated. Turns on at 200° F (93°c) and turns off at 180° F (82°c).
LAMP ON indicator	Indicates when searchlight Xenon lamp is on by lighting.
CIRCUIT TEST indicator	With CIRCUITS TEST switch in OPERATING POSITION, indicates malfunction in CIRCUIT TEST switch by lighting. With CIRCUIT TEST switch in positions 2 through 7, indicates malfunction in circuit under test by not lighting.
ELAPSED TIME meter	Measures total time of searchlight set operation in hours and tenths of hours.

Section II. OPERATION UNDER USUAL CONDITIONS

3-3. Heat Exchanger (figs. 1-2 and 1-3)

WARNING

Do not attempt any cleaning procedures while the searchlight is operating. The searchlight uses high voltages and current for operation which can cause serious injury.

The air intake and exhaust ducts on the heat exchanger must be free from obstructions before the equipment is operated. If necessary, flush water through air ducts to remove any dirt, insects, or other foreign matter which may restrict air circulation.

3-4. Preliminary Control Settings

(figs. 1-7 and 1-8)

The searchlight set may be operated in the spread, compact, or variable beam mode of operation. The preliminary control settings and the starting procedure are the same for all types of operation. Before starting the equipment (para 3-5), check the settings of the operating controls as follows:

Control	Position
Power switch	OFF.
CIRCUIT TEST switch	OPERATING POSITION.
Control switch	LOCAL.

3-5. Starting Procedure

(figs. 1-7 and 1-8)

NOTE

If an abnormal result is obtained during the starting procedure, refer to the operational checks (para 4-5, sequence Nos. 9 through 14). Refer to paragraph 3-4 before starting the equipment.

- a. Start the vehicle power source.

WARNING

Do not look directly into the searchlight beam. Blindness or serious eye damage may result. Do not operate the searchlight in the compact beam visible mode while personnel are within 320 meters of the beam path.

Personnel may suffer temporary flash blindness at ranges in excess of 320 meters when the searchlight is operated in either the compact beam or spread beam visible mode.

Do not operate the searchlight if the exhaust blower does not operate.

- b. Set the power switch to either the INFRARED or VISIBLE position, depending on the mode of operation required. The xenon lamp will ignite within 3 seconds,

the exhaust blower will operate, the LAMP ON indicator will light, and the CIRCUIT TEST indicator does not light.

- c. If the xenon lamp does not ignite, set the power switch to OFF and repeat the starting procedure. Do not try to ignite the xenon lamp after five or six attempts have been made.

- d. Check the air intake and exhaust ducts for airflow to make certain that the blower motor is operating.

- e. After 1 minute of xenon lamp operation, check to see that the OVER TEMP indicator is not lighted. Improper cooling at the searchlight will cause the OVER TEMP indicator to light.

CAUTION

Periodically check the OVER TEMP indicator during searchlight operation. The searchlight set will continue to operate even if an overheated condition exists. It is the responsibility of the operator to turn off the searchlight set if the OVER TEMP indicator lights.

3-6. Beam Width Adjustments

(figs. 1-7 and 1-8)

To adjust the beam width, start the searchlight set as described in paragraph 3-5, and proceed as follows:

- a. *Compact Beam Operation.* Place the beam switch to the COMPACT BEAM position. The searchlight beam width will automatically be adjusted until the narrowest beam width of approximately 1.0° is projected from the searchlight.

- b. *Spread Beam Operation.* Place the beam switch in the SPREAD BEAM position and hold until the widest beam width (7°) is projected from the searchlight.

- c. *Variable Beam Operation.* A variable beam width is obtained by holding the spring-loaded beam switch in the SPREAD BEAM (up) position. The light beam will spread from 1.0° to 7.0° width in 2 seconds. To hold the beam at any width between 1.0° and 7.0°, release the beam switch, allowing it to return to the center position. The beam will stay at the desired width until the beam switch is placed in either the SPREAD BEAM or COMPACT BEAM position. If the switch returned to SPREAD BEAM position, the searchlight beam will continue to spread to 7.0°. The beam spread may be stopped and held any number of times until the beam is fully spread at 7.0°. To return the beam to 1.0 (compact narrow beam), it is necessary to set the beam switch to the COMPACT BEAM position.

3-7. Modes of Operation

(figs. 1-7 and 1-8)

a. Visible Mode. Pull out on the power switch lever, move up to the VISIBLE position, and release.

b. Infrared Mode. Push the power switch lever to the INFRARED position; the switch will remain locked.

c. Remote Control. To control the searchlight from the remote control box, set the controls box as follows:

<i>Control</i>	<i>Position</i>
Power switch	OFF.
CIRCUIT TEST switch	OPERATING POSITION.
Control switch	REMOTE.

NOTE

If the control box power switch is at INFRARED or VISIBLE, power will be applied to the searchlight regardless of the position of the control switch on the control box.

3-8. Normal Stopping Procedure

(figs. 1-7 and 1-8)

CAUTION

Do not turn the searchlight off anywhere except at the control box or remote control box.

a. Set control box controls as follows:

(1) Place the beam switch to COMPACT BEAM and hold for 2 seconds, to release the strain on the reflector.

(2) Set the power switch to OFF. The Xenon lamp will turn off; the blower motor will continue to operate if the searchlight has been operating for more than 5 minutes.

WARNING

To prevent Xenon lamp explosion and possible injury to personnel, wait until the blower motor stops before continuing with the next procedure.

b. Shut off the vehicle power source.

c. Set all operating controls to the positions specified in paragraph 3-4.

3-9. Emergency Stopping Procedure

In an emergency, it may be necessary to turn off the searchlight set in the shortest possible time. To do this, shut off the vehicle power source that supplies power to the searchlight set.

Section III. OPERATION UNDER UNUSUAL CONDITIONS

3-10. Forging

(figs. 1-2 and 1-3)

CAUTION

Do not operate the searchlight when forging through deep water.

a. The searchlight can be forded through deep water without damaging the searchlight internal components. The window clamp contains a gasket which forms a waterproof seal for the window. The heat exchanger con-

tains a gasket which forms a waterproof seal between the heat exchanger and the searchlight housing.

b. Check to be sure that gaskets in the window clamp and heat exchanger are in good condition and that the clamp and the cover latches are properly closed. Water will flow into the heat exchanger through the open air intake and exhaust ducts without damaging the searchlight.

3-11. Operation in Arctic Climates
(figs. 1-2 and 1-3)

Subzero temperatures and climatic conditions associated with the cold weather affect efficient use of the equipment. Instructions and precautions for operations under such adverse conditions are as follows:

a. Frequently inspect the exterior of the searchlight and remove any accumulations of ice or snow, particularly around the window and the air intake and exhaust ducts.

b. Inspect the power cable, window clamp, and window for possible damage. Report defects to higher category of maintenance.

c. Cover the searchlight when it is not in operation.

3-12. Operation in Tropical Climates
(figs. 1-2 and 1-3)

When operated in tropical climates, moisture and humid conditions can cause problems with the searchlight. These conditions are particularly severe when the searchlight set is operated in swampy areas. Condensation of moisture on the equipment occurs frequently. To minimize the possibility of damage by moisture, take the following precautions:

a. Keep the equipment dry and clean.

b. Check all exterior parts frequently for evidence of corrosion and fungus formation.

c. Inspect the heat exchanger air intake and exhaust ducts and remove any obstructions.

d. Inspect the heat exchanger and window for a tight fit.

e. Inspect the front panels on the remote control box and control box for evidence of corrosion or fungus formation.

f. Properly tighten all electrical connectors.

g. Cover the searchlight when it is not in operation.

3-13. Operation in Desert Climates
(figs. 1-2 and 1-3)

Heat and dusty or sandy conditions are primary problems in desert areas. To minimize the possibility of damage by heat, dust, or sand, take the following precautions:

a. Remove the window or heat exchanger only when absolutely necessary,

b. Cover the searchlight with the canvas cover when the searchlight is not in operation. If possible, locate the searchlight in a sheltered area. Take advantage of any natural barrier which may offer protection from blowing dust.

c. Inspect the heat exchanger air intake and exhaust ducts. Flush the duct openings with water to remove any obstructions.

d. Keep the equipment clean.

3-14. Operation Under Salt Water Spray
Environments

Instructions and precautions for operation under salt water spray conditions are as follows:

a. Protect the searchlight from salt water spray. Wash it down regularly with fresh water and wipe dry with a clean, lint free cloth.

b. If permanent shelter is not available, protect the searchlight with the canvas cover when it is not in operation. Remove the cover during dry periods and allow the searchlight to dry out.

c. Inspect all painted surfaces for cracked, peeled, or blistered paint, and report discrepancies to higher category of maintenance.

CHAPTER 4 OPERATOR MAINTENANCE

Section I. GENERAL

4-1. Scope of Operator Maintenance

The maintenance duties assigned to the operator of the searchlight set are listed below together with a reference to the paragraphs covering the specific maintenance function. The duties assigned do not require tools or test equipment.

- a. Operator weekly preventive maintenance checks and services (para 4-5).
- b. Cleaning (para 4-6).

- c. Operator troubleshooting (para 4-8).

4-2. Materials Required for Operator Maintenance

The materials required for cleaning the searchlight are-

- a. Soft, clean, lint free cloth.
- b. Fresh water and mild soap.

Section II. OPERATOR PREVENTIVE MAINTENANCE

4-3. Preventive Maintenance

Preventive maintenance is the systematic care, servicing, and inspection of equipment to prevent the occurrence of trouble, to reduce downtime, and to assure that the equipment is serviceable.

a. *Systematic Care.* The procedures given in paragraphs 4-5 and 4-6 cover routine systematic care and cleaning essential to the proper upkeep and operation of equipment.

b. *Preventive Maintenance Checks and Services.* The preventive maintenance checks and services chart (para 4-5) outlines functions to be performed at specific intervals. These checks and services are to maintain Army electronic equipment in a combat-serviceable condition; that is, in good general (physical) condition and in good operating condition. The chart indicates what to check, how to check, and what the normal conditions are. The *References* column lists the illustrations or paragraphs containing detailed checks

and services procedures. If an abnormal condition is found and the defect cannot be remedied by the operator, higher category of maintenance or repair is required. Records and reports of these checks must be made in accordance with the requirements set forth in TM 38-750

4-4. Preventive Maintenance Checks and Services Required

Preventive maintenance checks and services of the searchlight set are required weekly. Paragraph 4-5 specifies checks and services that must be accomplished weekly and under the special conditions listed below.

- a. When the equipment is initially installed.
- b. When the equipment is reinstalled after removal for any reason.
- c. At least once each week if the equipment is maintained in a standby condition.

4-5. Operator Weekly Preventive Maintenance Checks and Services Chart

Sequence No.	Item to be inspected	Procedure	References
1	Exterior surfaces -----	Clean searchlight and control box panels -----	Para 4-6.
2	Heat exchanger -----	Clean air intake and exhaust ducts -----	Para 4-6.
3	Window -----	a. Clean window ----- b. Check glass for deep scratches or cracks -----	Para 4-6.

Sequence No.	Item to be inspected	Procedure	References
4	Reflector	a. Check for cleanliness b. Check surface area for scratches or discoloration	
5	Intercabling and connectors	Check all interconnecting cables and connectors for cracks and breaks.	
6	Searchlight mount	Check attaching parts for tight connections.	Fig. 1-9
7	Searchlight	Check for cracks, dents, or other evidence of damage.	
8	Knobs and switches	While making operational checks (items 9 through 12), observe that mechanical action of each knob and switch is smooth and free of binding. Set the following knobs and switches as indicated, before proceeding to step 9. Power switch OFF Control switch LOCAL Circuit test switch OPERATING POSITION Start engine and turn vehicle power switch to ON.	
9	Power switch	a. Set to VISIBLE : Note that CIRCUIT TEST indicator lamp does not light. Xenon lamp will ignite within 3 seconds, exhaust blower will operate, and LAMP ON indicator will light. After approximately 1 minute of Xenon lamp operation, see that OVER TEMP indicator is not lighted. b. If Xenon lamp does not light within 3 seconds, set to OFF , and repeat procedure. Do not attempt to ignite Xenon lamp after five or six attempts have been made. c. During visible mode of operation, adjust for spread beam, and then compact beam. Note that light beam varies in width. d. Set to INFRARED . Wait a few seconds, then note that: (1) LAMP ON indicator lamp lights in infrared mode. (2) Mode of operation changes from visible to infrared.	Para 3-5 Para 3-5 Para 3-6 Para 3-7
10	Control switch	a. Set to REMOTE . Repeat sequence 9. Note that the remote control box operates the searchlight. b. Set to LOCAL .	Para 3-7
11	ELAPSED TIME meter	During searchlight operation, check meter indicator for advanced readings.	Fig. 1-7
12	Blower motor	Set to VISIBLE . Wait 10 minutes, and then set to OFF . Heat exchanger blower motor must continue to operate.	Para 3-7
13	Searchlight shutdown	Follow procedure given in paragraph 3-8 to turn off searchlight. Turn vehicle power switch OFF . Stop the engine.	Para 3-8

4-6. Operator Cleaning Procedures

(figs. 1-2 and 1-3)

WARNING

To prevent injury to personnel, make sure that the searchlight set is turned off and cool before cleaning. Disconnect the power cable from the searchlight.

- a. Exterior Surfaces. The exterior surfaces should be clean; free of dust, dirt, grease, insects, and fungus.

CAUTION

Do not wash the exterior of the equipment with high-pressure hoses.

- (1) Wash the exterior of the searchlight with a low-pressure hose, or by using buckets of fresh water.
- (2) If dirt is difficult to remove, use a damp cloth or sponge and mild soap; then flush with fresh water.
- (3) When the exterior surface contains only dust or loose dirt, wipe it with a clean, soft cloth.
- (4) Remove grease, fungus, and ground-in dirt from the equipment surfaces by using a cloth and soap and water. Flush exterior surfaces with low-pressure fresh water. Dry equipment surfaces with a clean, lint free cloth.

b. *Heat Exchanger.* Remove foreign matter, such as insects and dirt, from heat exchanger air intake and exhaust ducts by flushing with low-pressure water.

c. *Window.* Clean the outside of the window with a clean, lint free cloth and fresh water. Gently wipe from the center to the outer edge. Do not use any cleaning solvents or abrasive compounds on the glass.

- d. Connect the power cable to the searchlight.

4-7. Lubrication

No lubrication of the AN/VSS-3 is required.

4-8. Operator Troubleshooting Procedures

Troubleshooting of this equipment by the operator is based on the operating checks described in paragraph 4-5, sequences Nos. 9 through 14. To troubleshoot the equipment, follow the operating checks until a trouble symptom is found, and then refer to paragraph 4-9. If the symptom is still present, report the malfunction to higher category of maintenance.

4-9. Operator Troubleshooting Chart

Item No.	Trouble symptoms	Probable trouble	Checks and corrective measures
1	Xenon lamp does not ignite; blower motor does not operate. LAMP ON indicator does not light.	<ul style="list-style-type: none"> a. Defective power cable b. Input power absent or level incorrect. 	<ul style="list-style-type: none"> a. Inspect power cable for defects, and tighten loose connections. b. Set CIRCUIT TEST switch to position 2. IF CIRCUIT TEST indicator does not light, check availability and level of input power.
2	Xenon lamp ignites; LAMP ON indicator lights; blower motor does not operate.	Blower motor inoperative due to obstruction.	Inspect air intake and exhaust ducts for obstruction and clean (para 4-6).
3	Xenon lamp flashes, but does not ignite.	Loose intercabling to control box	Inspect intercabling and tighten connectors.

CHAPTER 5 ORGANIZATIONAL MAINTENANCE

Section I. GENERAL

5-1. Scope of Organizational Maintenance

a. This chapter contains instructions covering organizational maintenance of the searchlight set. It includes instructions for performing preventive and periodic maintenance services and repair functions to be accomplished by the organizational repairman.

b. Organizational maintenance of the searchlight set includes-

- (1) Organizational monthly preventive maintenance checks and services chart (para 5-5).
- (2) Painting and refinishing (para 5-6).
- (3) Organizational troubleshooting (paras 5-8 and 5-9).
- (4) Repairs (paras 5-9 through 5-19).

5-2. Tools and Materials Required for Organizational Maintenance

- a.* Lamp and holder assembly.
- b.* Phillip's-type screwdriver.
- c.* Clean, lint free cloth.
- d.* Soap and water.
- e.* Alcohol.
- f.* Face mask.
- g.* Asbestos gloves.
- h.* Fine sandpaper.
- i.* Paint.
- j.* Protective apron.

Section II. ORGANIZATIONAL PREVENTIVE MAINTENANCE

5-3. Organizational Preventive Maintenance

a. Preventive maintenance is the systematic care, inspection, and servicing of equipment to maintain it in a serviceable condition, prevent breakdowns, and assure maximum operational capability. Preventive maintenance is the responsibility of all categories of maintenance concerned with the equipment and includes the inspection, testing, and repair or replacement of parts, subassemblies, or units that inspection and tests indicate would probably fail before the next scheduled periodic service. Preventive maintenance checks and services for the searchlight set at organizational maintenance are made at monthly intervals unless otherwise directed by the

commanding officer. The preventive maintenance checks and services should be scheduled concurrently with the maintenance checks and services schedule of the carrying vehicle.

b. Maintenance forms and records to be used and maintained on this equipment are specified in TM 38-750.

5-4. Organizational Monthly Maintenance

Monthly preventive maintenance checks and services on the searchlight set are required. All deficiencies must be recorded in accordance with the requirements of TM 38-750. Perform all the checks and services listed in paragraph 5-5 in the sequence listed.

5-5. Organizational Monthly Preventive Maintenance Checks and Services Chart

Sequence No.	Item to be inspected	Procedure	References
1	Completeness -----	See that equipment is complete -----	Para 1 - 6
2	Installation -----	See that equipment is properly installed -----	Para 2 - 4
3	Cleanliness -----	See that equipment is clean -----	Para 4 - 6

Sequence No.	Item to be inspected	Procedure	References
4	Preservation -----	Check all surfaces for evidence of fungus. Remove rust and corrosion. Paint bare spots.	Para 5-6
5	Publications -----	See that all publications are complete, serviceable, and current.	DA Pam 310-4
6	Modifications -----	Check DA Pam 310-7 to determine if new applicable MWO's have been published. ALL URGENT MWO's must be applied immediately. All NORMAL MWO's must be scheduled.	TM 38-750 and DA PAM 310-7
7	Spare parts -----	Check operator and organizational spare parts for general condition and method of storage. There should be no overstockage, and all shortages must be on valid requisitions.	App. B
8	Mounting -----	See that all exterior screws are tight -----	Fig. 1-9
9	Power cable -----	Inspect for corrosion, stripped threads, damaged insulation, and proper fit to receptacles. Replace cable if required.	Para 5-9
10	Canvas cover -----	Inspect for damaged material, tears, broken tiedown straps and proper fit with searchlight. Replace cover if worn or damaged.	Fig. 1-1
11	Searchlight -----	Perform operational check -----	Paras 3-4 through 3-8
12	CIRCUIT TEST switch -----	Set searchlight in operation in infrared mode ----- a. Set CIRCUIT TEST switch from positions 2 through 7. CIRCUIT TEST indicator must light. b. Set CIRCUIT TEST switch to OPERATING POSITION. CIRCUIT TEST INDICATOR must not light. c. If proper symptoms are not obtained, refer to troubleshooting procedures for corrective action.	Fig. 1-7 Paras 5-8 and 5-9.

5-6. Painting and Refinishing Procedure

Remove rust and corrosion from metal surfaces by sanding them lightly with fine sandpaper. Brush two thin coats of paint on the bare metal to protect it from further corrosion. Refer to applicable cleaning and refinishing practices and materials specified in SB 11-573 and TB 746-10.

5-7. Organizational Cleaning Procedures

organizational maintenance personnel are responsible for cleaning the reflector.

WARNING

Wear a face mask and asbestos gloves when working in the vicinity of the xenon lamp.

- a. Remove the window (para 5-11).
- b. Clean both sides of the window using soap and water. Rinse away soap and dry the window with a clean, lint free cloth.
- c. Clean the reflector using a clean, lint free cloth dampened with alcohol. Gently wipe from center to outer edge. Do not use any cleaning solvents or abrasive compounds on the reflector.
- d. Install the window (para 5-11).

Section III. ORGANIZATIONAL TROUBLESHOOTING AND REPAIRS

5-8. General

Troubleshooting of this equipment is based on the operational checks described in paragraph 4-5, steps 9 through 14. To troubleshoot the equipment, follow the operational checks until a trouble symptom is found, and then refer to the troubleshooting chart (para 5-9). Locate the trouble symptom in the chart, isolate the trouble using the CIRCUIT TEST switch and indicator, and perform the indicated corrective action. If the

trouble symptom is not listed, refer to higher category of maintenance. After performing each corrective action sequence, return to the starting procedure to check whether the trouble symptom is still present. If the symptom is still present, refer to higher category of maintenance.

NOTE

Check to be sure that the CIRCUIT TEST indicator lamp is not defective before starting the troubleshooting procedures.

5-9. Organizational Troubleshooting Chart

Item No.	Trouble symptom	Probable trouble	Checks and corrective measures
1	Xenon lamp does not ignite; blower motor does not operate; and LAMP ON indicator does not light.	<p>a. Input power absent or level incorrect.</p> <p>b. Defective power cable</p> <p>c. Defective cable to control box</p>	<p>a. Set CIRCUIT TEST switch to position 2. If CIRCUIT TEST indicator does not light, check availability and level of input power.</p> <p>b. Check input power cable for broken, burned, or shorted wires or loose connectors. Tighten connectors or replace defective cable.</p> <p>c. Check cable to control box for broken, burned, or shorted wires or loose connectors; tighten connectors.</p>
2	Xenon lamp does not ignite; blower motor operates; LAMP ON indicator lights.	<p>a. Input power level incorrect</p> <p>b. Open ballast resistor R1 or broken wires from rear cover to searchlight.</p> <p>c. Diode CR1 is defective</p> <p>d. Defective cable to control box</p> <p>e. Defective xenon lamp</p>	<p>a. Set CIRCUIT TEST switch to position 2. If CIRCUIT TEST indicator does not light, check level of input power.</p> <p>b. Set CIRCUIT TEST switch to position 3. If CIRCUIT TEST indicator does not light, ballast resistor R1 is defective or wires from rear cover to searchlight are broken. Refer to higher category of maintenance.</p> <p>c. Set CIRCUIT TEST switch to position 4. If CIRCUIT TEST indicator does not light, diode CR1 is defective. Refer to higher category of maintenance.</p> <p>d. Indicates open searchlight to control box cable or loose connectors; tighten connectors.</p> <p>e. Set CIRCUIT TEST switch from positions 2 through 7. If CIRCUIT TEST indicator lights in all positions, the xenon lamp is defective. Replace the xenon lamp (para 5-12).</p> <p style="text-align: center;">NOTE</p> <p>If after replacing the xenon lamp the lamp still will not ignite, re-install the original lamp in the searchlight and refer to higher category of maintenance.</p>
3	Xenon lamp ignites; blower does not operate; LAMP ON indicator lights.	<p>a. Input circuit to blower motor is defective.</p> <p>b. Blower motor is defective</p>	<p>a. Set CIRCUIT TEST switch to position 5. If CIRCUIT TEST indicator does not light, dc voltage is not being applied to the blower motor. Refer to higher category of maintenance.</p> <p>b. If CIRCUIT TEST indicator lights with the CIRCUIT TEST switch in position 5, blower motor is defective. Refer to higher category of maintenance.</p>
4	Xenon lamp ignites; blower motor operates; LAMP ON indicator does not light.	Defective LAMP ON indicator lamp 2A-1DS1.	Replace LAMP ON indicator lamp 2A1DS1 (para 5-18).
5	Searchlight does not change modes from INFRARED to VISIBLE.	Defective fuse 1A2F1	Replace fuse 1A2F1 (para 5-10).
6	After xenon lamp ignition, OVER TEMP indicator lights.	Cooling system ineffective due to obstructions.	Inspect intake and exhaust ducts for obstructions and clean (para 4-6).
7	Searchlight beam width is not adjustable with beam switch.	Defective fuse 1A2F2	Replace fuse 1A2F2 (para 5-10).

Item No.	Trouble symptom	Probable trouble	Checks and corrective measures
8	Searchlight operates from control box but not from remote control box.	a. Defective cable from control box to remote control box. b. Defective control switch -----	a. Check cable from control box to remote control box for breaks or loose connector; tighten connectors. b. Refer to higher category of maintenance.
9	ELAPSED TIME meter does not advance during searchlight operation.	ELAPSED TIME meter is defective	Refer to higher category of maintenance.

Section IV. REPAIRS

5-10. Replacement of Fuses

(fig. 1-4)

WARNING

To prevent injury to personnel, insure that the searchlight set is turned off. Disconnect the power cable from the searchlight.

a. Unlatch the six latches on the heat exchanger and carefully remove it from the searchlight housing. Leave wiring attached to the heat exchanger.

CAUTION

Always replace a blown fuse with one of

the same rating. If a replacement fuse blows, do not install another fuse until the trouble has been remedied.

b. Replace fuse 1A2F1 or 1A2F2 as required and reattach heat exchanger to searchlight housing. Fasten the six latches,

c. Connect the power cable to the searchlight.

NOTE

The chart below lists the fuses used in the power distribution system of the searchlight set. The chart indicates the rating, use, indication of blown fuse, and location of fuses within the set.

Fuse	Rating		Blown fuse indication	Location
	Volts	Amps		
1A2F1	250	1 (slow blow) ---	Searchlight will not switch modes from IR to visual.	Rear of searchlight support assembly.
1A2F2	250	1 (slow blow) ---	Searchlight beam width will not vary -----	Rear of searchlight support assembly.

5-11. Replacement of Window

(fig. 5-1)

WARNING

To prevent injury to personnel, insure that the searchlight set is turned off. Disconnect the power cable from the searchlight. The window must not be removed until the searchlight has been off for at least 15 minutes.

CAUTION

To prevent glass breakage, the window must be carefully removed from the searchlight. The window is held in place by the window clamp which surrounds the perimeter of the window.

a. Remove the window as follows:

(1) Release the safety bail from the window clamp handle.

(2) Unlatch the window clamp.

(3) Remove the window and window seal.

b. Install the window as follows:

(1) Place the window seal around the perimeter of window.

(2) Hold window in proper position against housing flange.

(3) Place clamp evenly around window and housing flange.

(4) Latch the clamp into place.

(5) Secure clamp handle with safety bail.

NOTE

The handle of the window clamp is spring-loaded and will snap into place.

(6) Connect the power cable to the searchlight.

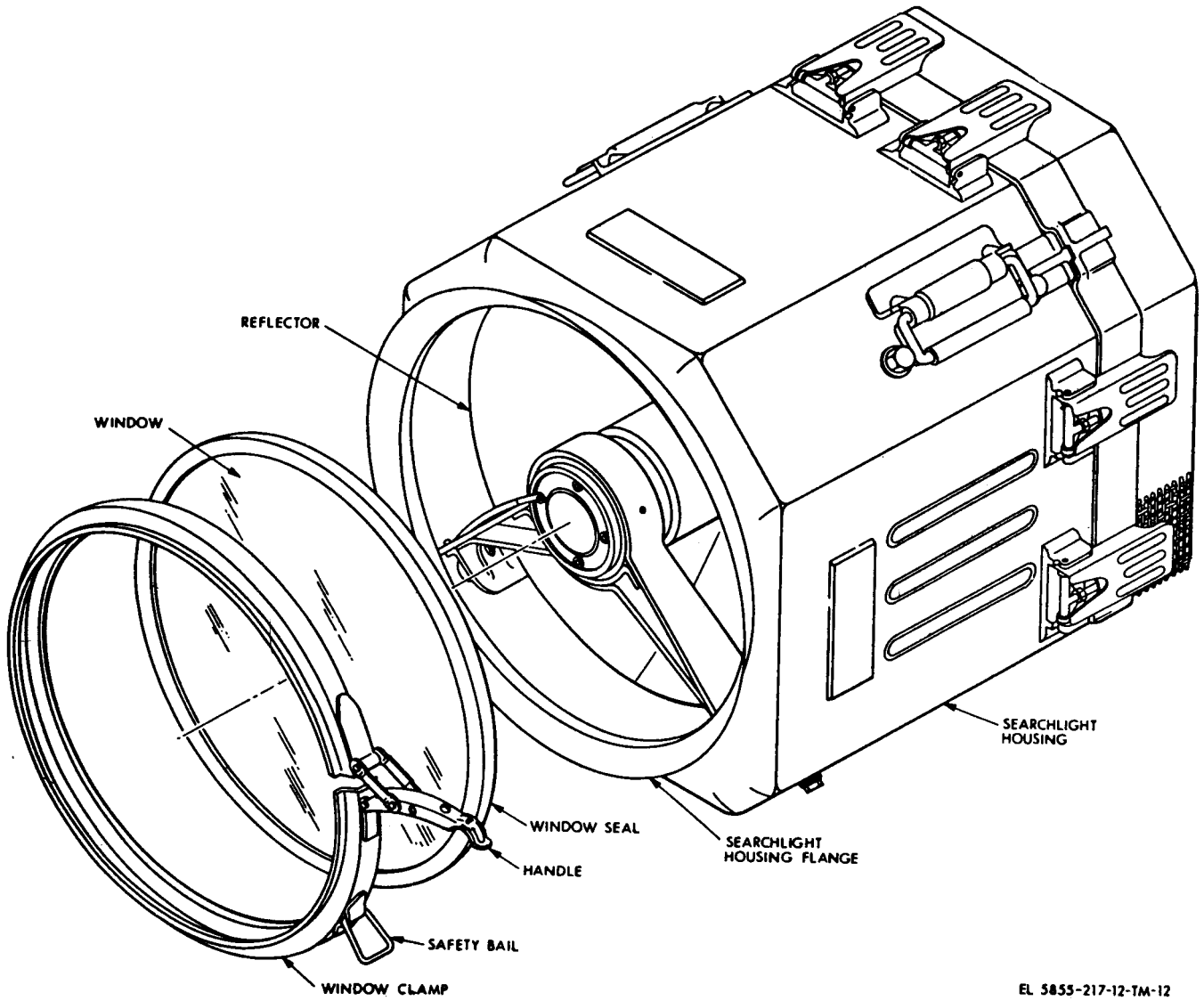

Figure 5-1. Searchlight, window replacement, exploded view.

5-12. Replacement of Xenon Lamp

(fig. 5-2)

WARNING

The Xenon lamp is under high internal pressure and must be handled carefully. If dropped or given a sharp blow, it can explode violently.

The glass envelope of the lamp must never be touched with bare hands, dirty gloves, or rags. Finger acids and dirt can cause spots on the envelope which, in turn, can cause violent failure of the lamp.

The spare lamp is contained inside a lampholder and held in place by tape covering the open end of holder. The holder is also used as a tool for removing and installing the lamp. To insure personal safety during lamp replacement, lamp must always remain inside the holder until lamp installation has been completed.

Wear a face mask, asbestos gloves, and a protective apron when removing and replacing the Xenon lamps.

The window should not be removed or the Xenon lamp worked on until the searchlight has been off for at least 15 minutes.

NOTE

Bury or discard lamp to avoid personnel coming in contact with Xenon lamp inside lampholder.

To replace the Xenon lamp, perform the following steps:

a. Disconnect the power cable at searchlight to prevent accidental shock.

b. Release the safety bail (1) on the handle of the clamp (2). Remove the clamp and carefully lift the window and window seal (3) away from the searchlight housing (12).

NOTE

Leave the window seal around the perimeter of the window.

c. Remove and retain the four screws (4), lockwashers (5), and flat washers (6) that hold the wire terminal (not shown) to the lamp support (7); remove the lamp support (7) from the bipod assembly (11).

d. Carefully pull the lamp support (7) away from bipod assembly (11).

e. Insert an empty lampholder through the opening in bipod assembly (11) and slide it inward until the end of travel is felt.

f. Unscrew the xenon lamp counterclockwise, using the lampholder as a tool.

g. Remove the xenon lamp and the lampholder from the bipod assembly (11). Tape the open end of the lampholder to prevent the xenon lamp from slipping out.

h. Install the replacement lamp and holder assembly (8) through the opening in the bipod assembly (11).

i. Carefully turn the lampholder (9) clockwise until the xenon lamp (10) is snugly fastened into place.

- | | |
|--|---------------------------------|
| 1 Safety ball (part of window clamp) | 7 Lamp support (1A2A12) |
| 2 Window clamp (1MP6) | 8 Lamp and holder assembly (A1) |
| 3 Window (1MP5) and window seal (1MP7) | 9 Lampholder (A1MP1) |
| 4 Screw (1A2H25-4) | 10 Xenon lamp (A1DS1) |
| Lockwasher (1A2H67-4) | 11 Bipod assembly (1A2A10) |
| Flat washer (1A2H36-4) | 12 Searchlight housing (1A1) |

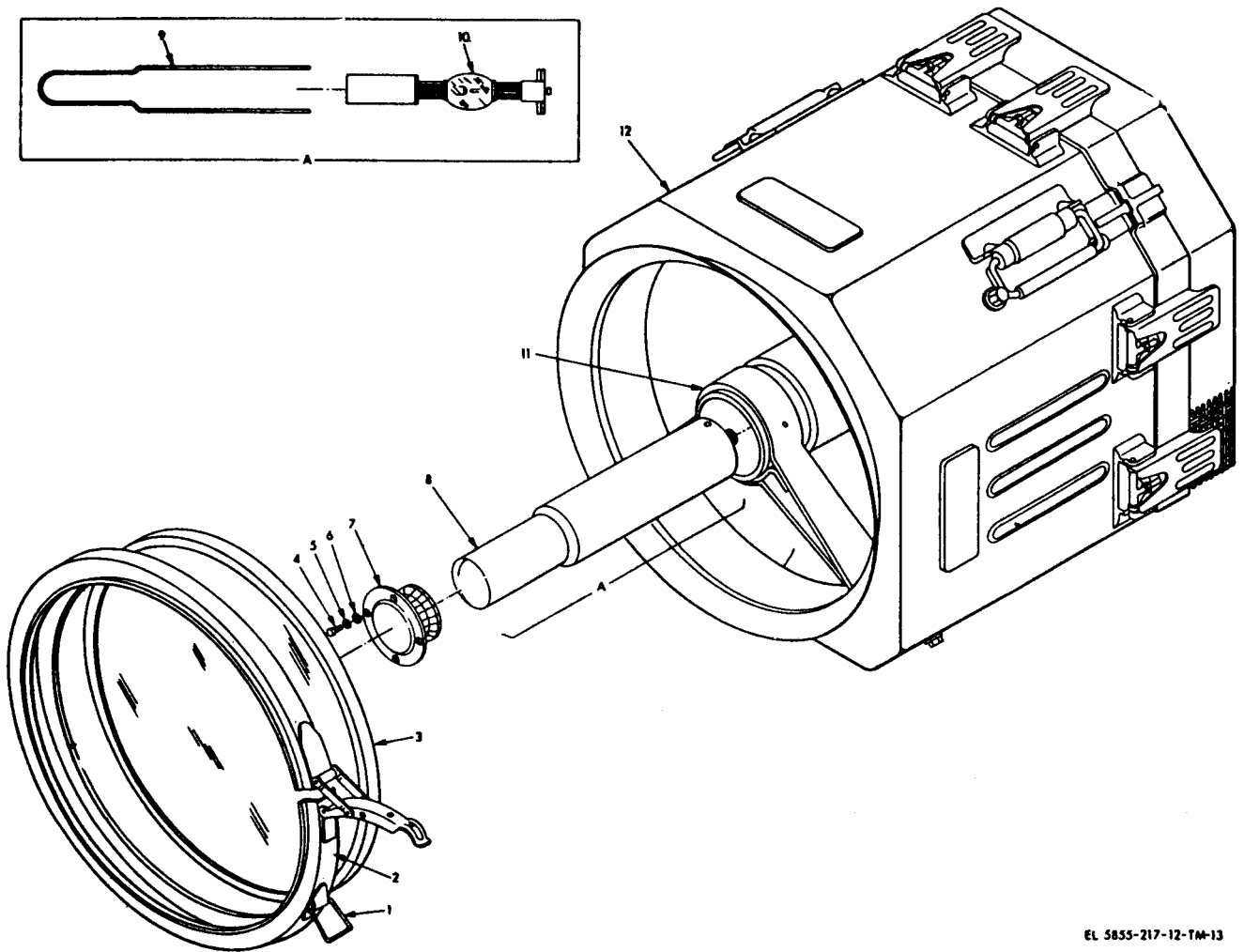

EL 5855-217-12-TM-13

Figure 5-2. Searchlight, xenon lamp replacement, exploded view.

j. Remove the lampholder from the bipod assembly. Save the lampholder for use as a tool for future lamp replacement. Insert the lamp support (7) into place by aligning the four mounting holes with four threaded holes on the face of the bipod assembly.

CAUTION

Be sure to attach the wire terminal (not shown) to lamp support. Use one of lamp support mounting screws (4) to hold the terminal in place.

k. Install the four screws (4) and washers (5 and 6) to secure the lamp support (7) to the bipod assembly (11). Make sure that all four screws are tight.

l. Carefully install the window and window seal (3) on the searchlight housing (12). Secure the window in place with the window clamp (2) and safety bail (1).

m. Connect the power cable to the searchlight.

5-13. Replacement of Searchlight

WARNING

To prevent injury to personnel, turn off the searchlight set and disconnect the cable connected to receptacle J1 on the control box.

a. Remove the searchlight from the vehicle as follows :

(1) Disconnect the power cable from the searchlight.

(2) Disconnect and remove the three mounting pins that hold the searchlight mount to the vehicle support while the searchlight is held by the carrying handles by two men.

(3) Lift the searchlight off the vehicle support and remove it from the vehicle.

b. Replace the searchlight on the vehicle as follows :

(1) Lift searchlight into the vehicle support and align the vehicle support with the searchlight mount.

(2) Install the three mounting pins to connect the searchlight mount to the vehicle support.

(3) Connect the power cable to the searchlight.

(4) Connect the cable to receptacle J1 on the control box.

5-14. Replacement of Searchlight Mount

(fig. 1-9)

a. Remove the searchlight mount as follows:

(1) Remove the searchlight from the vehicle (para 5-13).

(2) Set the searchlight down with the searchlight mount facing up.

(3) Use a suitable wrench to remove the mounting (cap) screws and flat washers that attach the mount to the searchlight.

b. Replace the searchlight mount as follows:

(1) Position the searchlight mount on searchlight as shown in figure 1-9.

(2) Install the mounting (cap) screws and flat washers into searchlight mount and tighten with wrench.

(3) Replace the searchlight to the vehicle (para 5-13)

5-15. Replacement of Control Box

(fig. 1-1)

a. Remove the control box from the vehicle as follows :

WARNING

To prevent injury to personnel, turn off the searchlight and vehicle power source.

(1) Tag and disconnect all connecting cables (not shown) attached to the control box.

(2) Remove the four mounting screws (11) and lockwashers (12) that secure the control box mounting plate to the vehicle.

(3) Remove control box from vehicle.

b. Replace control box in vehicle as follows:

(1) Position the control box so that the four holes in mounting plate are aligned with the four mounting holes in the vehicle.

(2) Install and tighten the four mounting screws (11) and lockwashers (12) that secure the control box to the vehicle.

c. Attach the connecting cables to the proper receptacles on the control box.

5-16. Replacement of Power Cable

WARNING

To prevent injury to personnel, turn off the searchlight set and disconnect the cable at J1 on the control box.

a. Disconnect the power cable at the searchlight.

b. Disconnect power cable at the vehicle receptacle.

c. Attach the replacement power cable plug to

the receptacle on the searchlight. Be sure to plug the cable firmly into the receptacle before tightening the cable retainer.

d. Attach the other end of the replacement power cable to the vehicle receptacle.

5-17. Replacement of Remote Control Box
(fig. 1-1)

a. Remove remote control box from vehicle as follows:

WARNING

To prevent injury to personnel, turn off the searchlight and vehicle power source.

(1) Disconnect the remote control box interconnecting cable (not shown) from receptacle 3J1 on the remote control box.

(2) Remove the four mounting screws (7) and lockwashers (8) that secure the remote control box mounting plate to the vehicle.

(3) Remove the remote control box from the vehicle.

b. Replace remote control box in vehicle as follows:

(1) Position the remote control box so that the four mounting holes in the mounting plate are aligned with the four mounting holes in the vehicle.

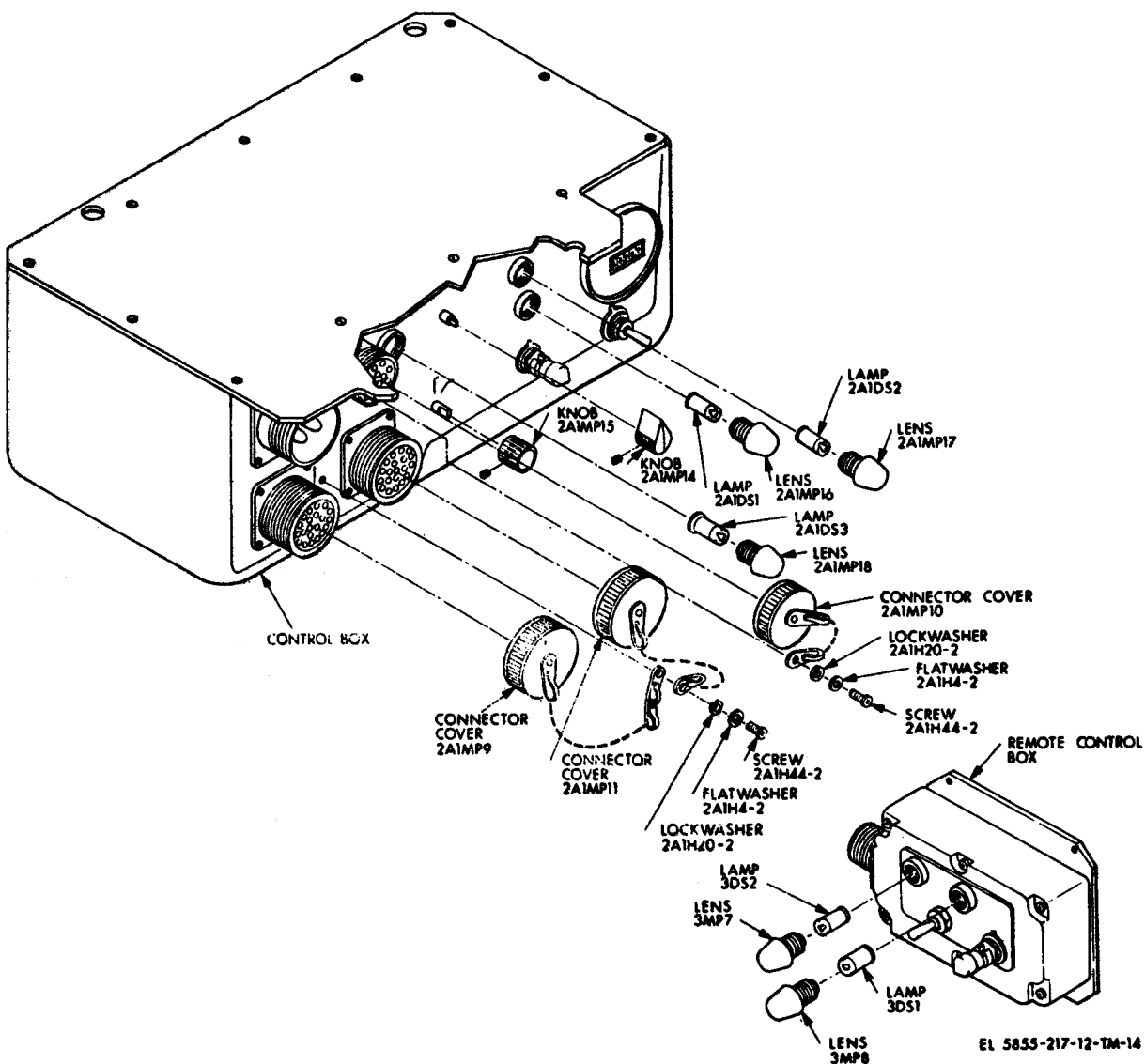

Figure 5-3. Replacement of indicator lamps.

(2) Install and tighten the four mounting screws (7) and lockwashers (8) through the mounting plate into the vehicle.

(3) Attach the remote control box interconnecting cable (not shown) to receptacle 3J1 on the remote control box.

5-18. Replacement of Indicator Lamps

(fig. 5-3)

a. Control box.

(1) Locate the defective indicator and remove from the control box by turning the indicator lens counterclockwise.

(2) Remove the defective indicator lamp from the indicator lens.

(3) Insert the replacement indicator lamp in the lens and install into the control box. Tighten the lens by turning it clockwise.

b. Remote Control Box. Follow the same procedure for replacement of defective indicator lamps as described for the control box (*a* above).

5-19. Replacement of Switch Knobs

(fig. 5-3)

a. Circuit Test Switch Knob.

(1) Loosen the setscrew by turning it counterclockwise.

(2) Remove the knob from the switch.

(3) Insert the replacement knob on the switch.

(4) Tighten the setscrew by turning it clockwise.

b. Control Switch Knob. Follow the same procedure for replacement of a defective knob as described in *a* above.

CHAPTER 6

SHIPMENT, LIMITED STORAGE, AND DEMOLITION TO PREVENT ENEMY USE

Section I. SHIPMENT AND LIMITED STORAGE

6-1. Disassembly

- a. Remove the searchlight (para 5-13).
- b. Remove the control box (para 5-15).
- c. Remove the remote control box (para 5-17).
- d. Remove the power cable (para 5-16).

6-2. Shipment or Limited Storage

a. *Shipment.* Package the searchlight set as shown in figure 2-1, and in accordance with SB 38-100.

b. *Limited Storage.* When the searchlight set

is to be stored for a limited time, perform the following procedures:

(1) Inventory all components to be sure that the equipment is complete and serviceable. Unserviceable spare parts or components should be repaired or replaced.

(2) Thoroughly clean the equipment (paras 4-6 and 5-7).

(3) Remove all traces of rust and corrosion and repaint surfaces that have been damaged (para 5-6).

(4) Place the canvas cover over the searchlight.

Section II. DEMOLITION OF MATERIEL TO PREVENT ENEMY USE

6-3. Authority for Demolition

Demolition of the equipment will be accomplished only upon the order of the commander. The demolition procedures given in paragraph 6-4 will be used to prevent the enemy from using or salvaging this equipment.

6-4. Destruction Plan

Field manuals direct that a destruction plan for equipment will be prepared. Personnel should be assigned specific tasks so that minimum time will be required if destruction is necessary. Personnel should be familiar with all aspects of the overall destruction plan. The plan must be complete, adequate, capable of being easily carried out in the field, and provide for destruction as complete as the available time, equipment, and personnel will permit. Because the time required for complete destruction may not always be available, field manuals also direct that destruction priorities be established to insure that essential parts of equipment will be destroyed first. Priority in the following order is suggested for the searchlight set:

- a. The highest priority for destruction should

be given to the major components which are most essential for searchlight operation; the xenon lamp, reflector, infrared filter assembly, control box, and remote control box.

b. Destroy the minor components; the searchlight window, heat exchanger, searchlight housing, and power cable.

c. The technical manual is to be destroyed after the minor components are destroyed.

d. The spare parts and the searchlight cover are the last items in the order of destruction.

6-5. Methods of Destruction

Any or all of the methods of destruction given below may be used. In most instances, the available time will be the major determining factor as to the method to be used for destroying equipment. The tactical situation will also determine how the destruction order will be carried out. However, in most cases it is preferable to completely demolish some portions of the equipment rather than to partially destroy all the equipment. The destruction methods described below are given

in order of preference. Burning is the preferred method.

a. Burning. Burn as much of the searchlight set as is flammable by using gasoline, kerosene, and flamethrowers. Remove the window and heat exchanger; pour gasoline on all components inside the searchlight housing and inside the control box, and on the technical manual, remote control box, power cable, spare parts, and searchlight cover and ignite.

b. Explosives. Powder charges, fragmentation grenades, or incendiary grenades may be used in any of the applications given below.

WARNING

Be extremely careful in the use of explosives and incendiary devices. These items should not be used unless extreme emergency demands their use.

(1) Remove the window or heat exchanger and place a charge or grenade inside the searchlight housing.

(2) Pile the remote control box, control box, power cable, technical manual, spare parts, and canvas cover and attach a charge or grenade in the middle of the pile.

c. Small Arms Fire. Rifles or other similar weapons may be used to complete destruction when time does not permit demolition by any other means.

WARNING

Be extremely careful when using small arms fire. Glass and metal fragments may spray back in direction of the person firing.

(1) From a safe distance, direct the available firepower toward the window of the searchlight. Be sure to destroy the xenon lamp, infrared filter assembly, and reflector.

(2) Direct firepower toward the heat exchanger.

(3) Destroy the remote control box, control box, and power cable.

(4) Destroy the technical manual, spare parts, and canvas cover.

d. Smashing. Use sledges, axes, hammers, crow-bars, and any other heavy tools available to smash the interior components mounted inside the searchlight, remote control box, and control box.

WARNING

Be extremely careful when smashing the searchlight. Glass and metal fragments may spray in the direction of the person using the tool.

(1) Use the heaviest tool on hand to smash the searchlight.

(2) Smash the front panels of the control box and remote control box until all parts are destroyed.

(3) Use an axe or hatchet to cut the interconnecting cables in several places. If time permits, open the units of the set and slash the internal wiring.

6-6. Methods of Disposal

Bury or scatter destroyed parts and miscellaneous repair parts, or throw them into nearby waterways. This is particularly important if a number of parts have not been completely destroyed.

APPENDIX A

REFERENCES

The following is a list of applicable references available to the operator and organizational maintenance personnel of Searchlight Set, Infrared AN/VSS-3:

PA Pam 310-4	Index of Technical Manuals, Technical Bulletins, Supply Manuals (types 7, 8, and 9), Supply Bulletins, and Lubrication Orders.
DA Pam 310-7	U. S. Army Equipment Index of Modification Work Orders.
SB 11-573	Painting and Preservation Supplies Available for Field Use for Electronic Command Equipment.
SB 38-100	Preservation, Packaging, Packing and Marking Materials, Supplies, and Equipment Used by the Army.
TB 746-10	Field Instructions for Painting and Preserving Electronics Command Equipment.
TB SIG 291	Safety Measures to be Observed When Installing and Using Whip Antenna, Field Type Masts, Towers, Antennas, and Metal Poles that are Used with Communication, Radar, and Direction Finder Equipment.
TM 38-750	Army Equipment Record Procedures.

APPENDIX B BASIC ISSUE ITEMS LIST (BIIL) AND ITEMS TROOP INSTALLED OR AUTHORIZED LIST (ITIAL)

Section I. INTRODUCTION

1. Scope

This appendix lists basic issue items and items troop installed or authorized required by the crew/operator for installation, operation, and maintenance of Crew/Operator.

2. General

This Basic Issue Items and Items Troop Installed or Authorized List is divided into the following sections:

a. Basic Issue Items List - Section II. A list, in alphabetical sequence, of items which are furnished with, and which must be turned in with the end item.

b. Items Troop Installed or Authorized List - Section III. A list, in alphabetical sequence, of items which, at the discretion of the unit commander, may accompany the end item, but are not subject to be turned in with the end item.

3. Explanation of Columns

The following provides an explanation of columns found in the tabular listings:

a. Illustration. This column is divided as follows:

(1) *Figure number.* Indicates the figure number of the illustration in which the item is shown.

(2) *Item Number.* Not applicable.

b. Federal Stock Number. Indicates the Federal

stock number assigned to the item and will be used for requisitioning purposes.

c. Part Number. Indicates the primary number used by the manufacturer (individual, company, firm, corporation, or government activity), which controls the design and characteristics of the item by means of its engineering drawings, specifications, standards, and inspection requirements, to identify an item or range of items.

d. Federal Supply Code for Manufacturer (FSCM). The FSCM is a 5-digit numeric code used to identify the manufacturer, distributor, or Government agency, etc., and is identified in SB 708-42.

e. Description. Indicates the Federal Item name and a minimum description required to identify the item.

f. Unit of Measure U/M. Indicates the standard of basic quantity of the listed item as used in performing the actual maintenance function. This measure is expressed by a two-character alphabetical abbreviation, (e.g., ea, in, pr, etc.).

g. Quantity Furnished with Equipment (Basic Issue Items Only). Indicates the quantity of the basic issue item furnished with the equipment.

h. Quantity Authorized (Items Troop Installed or Authorized Only). indicates the quantity of the item authorized to be used with the equipment.

Section II. BASIC ISSUE ITEMS LIST

(1) Illustration		(2) Federal stock number	(3) Part number	(4) FSCM	(5) Description	Usable on code	(6) Unit of meas	(7) Qty furn with equip
(A) Fig. No.	(B) Item No.							
1-1		5975-123-1527	1127001-1	12705	COVER, SEARCHLIGHT		EA	1

Section III. ITEMS TROOP INSTALLED OR AUTHORIZED LIST

(1) Federal stock number	(2) Part number	(3) FSCM	(4) Description	Usable on code	(5) Unit of meas	(6) Qty auth
6250-134-1757	1126904	12705	HOLDER, LAMP		EA	1

APPENDIX C

MAINTENANCE ALLOCATION

Section I. INTRODUCTION

C-1. General

This appendix provides a summary of the maintenance operations covered in the equipment literature for the AN/VSS-3. It authorizes categories of maintenance for specific maintenance functions on repairable items and components and the tools and equipment required to perform each function. This appendix may be used as an aid in planning maintenance operations.

C-2. Maintenance Functions

Maintenance functions will be limited to and defined as follows:

a. Inspect. To determine serviceability of an item by comparing its physical, mechanical, and electrical characteristics with established standards.

b. Test. To verify serviceability and to detect incipient electrical or mechanical failure by use of special equipment such as gages, meters, etc. This is accomplished with external test equipment and does not include operation of the equipment and operator type tests using internal meters or indicating devices.

c. Service. To clean, to preserve, to charge, and to add fuel, lubricants, cooling agents, and air. If it is desired that elements, such as painting and lubricating, be defined separately, they may be so listed.

d. Adjust. To rectify to the extent necessary to bring into proper operating range.

e. Align. To adjust two or more components or assemblies of an electrical *or* mechanical system so that their functions are properly synchronized. This does not include setting the frequency control knob of radio receivers or transmitters to the desired frequency.

f. Calibrate. To determine the corrections to be made in the readings of instruments or test equip-

ment used in precise measurement. Consists of the comparison of two instruments, one of which is a certified standard of known accuracy, to detect and adjust any discrepancy in the accuracy of the instrument being compared with the certified standard.

g. Install. To set up for use in an operational environment such as an encampment, site, or vehicle.

h. Replace. To replace unserviceable items with serviceable like items.

i. Repair. To restore an item to serviceable condition through correction of a specific failure or unserviceable condition. This function includes, but is not limited to welding, grinding, riveting, straightening, and replacement of parts other than the trial and error replacement of running spare type items such as fuses, lamps, or electron tubes.

j. Overhaul. Normally, the highest degree of maintenance performed by the Army in order to minimize time work in process is consistent with quality and economy of operation. It consists of that maintenance necessary to restore an item to completely serviceable condition as prescribed by maintenance standards in technical publications for each item of equipment. Overhaul normally does not return an item to like new, zero mileage, or zero hour condition.

k. Rebuild. The highest degree of materiel maintenance. It consists of restoring equipment as nearly as possible to new condition in accordance with original manufacturing standards. Rebuild is performed only when required by operational considerations or other paramount factors and then only at the depot maintenance category. Rebuild reduces to zero the hours or miles the equipment, or component thereof, has been in use.

l. Symbols. The uppercase letter placed in the appropriate column indicates the lowest level at

which that particular maintenance function is to be performed.

C-3. Explanation of Format

a. Column 1, Group Number. Column 1 lists group numbers, the purpose of which is to identify components, assemblies, subassemblies and modules with the next higher assembly.

b. Column 2, Functional Group. Column 2 lists the noun names of components, assemblies, subassemblies and modules on which maintenance is authorized.

c. Column 3, Maintenance Functions. Column 3 lists the maintenance category at which performance of the specific maintenance function is authorized. Authorization to perform a function at any category also includes authorization to perform that function at higher categories. The codes used represent the various maintenance categories as follows:

<i>Code</i>	<i>Maintenance Category</i>
C	Operator/crew
O	Organizational maintenance
F	Direct support maintenance
H	General Support Maintenance
D	Depot maintenance

d. Column 4, Tools and Test Equipment. Col-

umn 4 specifies, by code, those tools and test equipment required to perform the designated function. The numbers appearing in this column refer to specific tools and test equipment which are identified in table I.

e. Column 5, Remarks. Self-explanatory.

C-4. Explanation of Format of Table I, Tool and Test Equipment Requirements

The column in table I are as follows:

a. Tools and Equipment. The numbers in this column coincide with the numbers used in the tools and equipment column of the maintenance allocation chart. The numbers indicate the applicable tool for the maintenance function.

b. Maintenance Category. The codes in this column indicate the maintenance category normally allocated the facility.

c. Nomenclature. This column lists tools, test, and maintenance equipment required to perform the maintenance functions.

d. Federal Stock Number. This column lists the Federal stock number of the specific tool or test equipment.

e. Tool Number. Not used.

SECTION II. MAIN ALLOCATION CHART

GROUP NUMBER	COMPONENT ASSEMBLY NOMENCLATURE	MAINTENANCE FUNCTIONS										TOOLS AND EQUIPMENT	REMARKS	
		INSPECT	TEST	SERVICE	ADJUST	ALIGN	CALIBRATE	INSTALL	REPLACE	REPAIR	OVERHAUL			REBUILD
1	SEARCHLIGHT, INFRARED AN/VSS-3	C	O F	C				O		O F			5,6,7 1 thru 7 1 thru 7	Depot facilities
	SEARCHLIGHT, INFRARED MX-8272/VSS-3	C	F	C					O	O F			5,6,7 1,2,4 thru 7	
	1A2 MAIN FRAME ASSY	F	F				F			O F			5,6,7 1,2,4 thru 7	
	1A2E4 STARTER BOOSTER	F							F				4	
	1A2A8 INFRARED FILTER ASSY	F	D						F		D		4	
	1A2A4 FOCUS MOTOR ASSY	F	F		F					F			1,2,4	
	1A2E3 IGNITER	F								F			4	
	1A2DS1 XENON LAMP	O								O			5 thru 7	
	1A2A11 REFLECTOR	F								F			4	
	1A3 REAR COVER ASSY	C	F	C							F		1,2,4	
	1A3A1 BALLAST RESISTOR	F	F							F			1,4	
	1A3A4 BLOWER MOTOR ASSY	F	F							F	F		1,2,4	
	BRUSHES									F			4	
	FRONT COVER ASSY	C		C						O				

MAINTENANCE ALLOCATION CHART

GROUP NUMBER	COMPONENT ASSEMBLY NOMENCLATURE	MAINTENANCE FUNCTIONS										TOOLS AND EQUIPMENT	REMARKS			
		INSPECT	TEST	SERVICE	ADJUST	ALIGN	CALIBRATE	INSTALL	REPLACE	REPAIR	OVERHAUL			REBUILD		
2	AN/VSS-3 (continued) CONTROL BOX C-7905/VSS-3	C		C												
2A1A3	PRINTED CIRCUIT BOARD	F	F											1,2,4		
3	REMOTE CONTROL BOX C-7906/VSS-3	C	D											4		
4	CABLE ASSY CX-11893/VSS-3	C	F	C										1,2,4		
		O	F	O										1,4		

TABLE 1. TOOL AND TEST EQUIPMENT REQUIREMENTS

TOOLS AND EQUIPMENT	MAINTENANCE CATEGORY	NOMENCLATURE	FEDERAL STOCK NUMBER	TOOL
		AN/VSS-3 (continued)		
1	F, H, D	MULTIMETER AN/USM-223 (USE TS-352B/U UNIT) AVAILABLE)	6625-999-7465	
2	F, H, D	POWER SUPPLY PP-1656/G	6130-985-8130	
3	F, H, D	STOPWATCH	6645-719-8760	
4	F, H, D	TOOL KIT TK-100/G	5180-605-0079	
5	O, F, H, D	APRON, BLACKSMITH, LEATHER	8415-234-9254	
6	O, F, H, D	FACE SHIELD	4240-965-1269	
7	O, F, H, D	GLOVES, ASBESTOS	8415-564-5191	

APPENDIX D

ORGANIZATIONAL MAINTENANCE REPAIR PARTS AND SPECIAL TOOLS LIST

Section i. INTRODUCTION

D-1. Scope

This appendix lists repair parts and special tools required for the performance of organizational maintenance of the AN/VSS-3.

D-2. General

This repair parts and special tools list is divided into the following sections:

a. Prescribed Load Allowance (PLA)-Section II. A composite listing of the repair parts, special tools, test and support equipment having quantitative allowance for initial stockage at the organizational level.

b. Repair Parts-Section III. A list of repair parts authorized for the performance of maintenance of the organizational level.

c. Special Tools, Test and Support Equipment-Section IV. Not applicable.

d. Federal Stock Number and Reference Number Index-Section V. A list of Federal stock numbers in ascending numerical sequence followed by a list of reference numbers in ascending alphanumeric sequence, cross-referenced to the illustration figure number and item number.

e. Reference Designation Cross-Reference to Page Number-Section VI. A list of reference designations cross-referenced to page number.

D-3. Explanation of Columns

The following provides an explanation of columns in the tabular lists:

a. Source, Maintenance, and Recoverability Codes (SMR), Column 1.

(1) Source codes indicate the selection status and source for the listed item. Source codes are -

<i>Code</i>	<i>Explanation</i>
P	-Repair parts which are stocked in or supplied from the GSA/DSA, or Army

<i>Code</i>	<i>Explanation</i>
	supply system and authorized for use at indicated maintenance categories.
P2	-Repair parts which are procured and stocked for insurance purposes because the combat or military essentiality of the end item dictates that a minimum quantity be available in the supply system.
P9	-Assigned to items which are NSA design controlled: unique repair parts, special tools, test, measuring and diagnostic equipment, which are stocked and supplied by the Army COMSEC logistic system, and which are not subject to the provisions of AR 380-41.
P10	-Assigned to items which are NSA design controlled: special tools, test, measuring and diagnostic equipment for COMSEC support, which are accountable under the provisions of AR 380-41, and which are stocked and supplied by the Army COMSEC logistic system.
M	-Repair parts which are not procured or stocked, but are to be manufactured in indicated maintenance levels.
A	-Assemblies which are not procured or stocked as such, but are made up of two or more units. Such component units carry individual stock numbers and descriptions, are procured and stocked separately and can be assembled to form the required assembly at indicated maintenance categories.
X	-Parts and assemblies which are not procured or stocked and the mortality of which normally is below that of the applicable end item or component. The failure of such part or assembly should result in retirement of the end item from the supply system.
X1	-Repair parts which are not procured or stocked. The requirement for such items

- | <i>Code</i> | <i>Explanation</i> |
|-------------|---|
| | will be filled by use of the next higher assembly or component. |
| X2 | -Repair parts which are not stocked. The indicated maintenance category requiring such repair parts will attempt to obtain same through cannibalization. Where such repair parts are not obtainable through cannibalization, requirements will be requisitioned, with accompanying justification, through normal supply channels. |
| G | -Major assemblies that are procured with PEMA funds for initial issue only as exchange assemblies at DSU and GSU level. These assemblies will not be stocked above DS and GS level or returned to depot supply level. |

(2) Maintenance codes indicate the lowest category of maintenance authorized to install the listed item. The maintenance level codes are-

- | <i>Code</i> | <i>Explanation</i> |
|-------------|----------------------------|
| C | Operator/crew |
| O | Organizational maintenance |

(3) Recoverability codes indicate whether unserviceable items should be returned for recovery or salvage. Items not coded are expendable. Recoverability codes are-

- | <i>Code</i> | <i>Explanation</i> |
|-------------|---|
| R | -Repair parts and assemblies that are economically repairable at DSU and GSU activities and are normally furnished by supply on an exchange basis. |
| S | -Repair parts and assemblies which are economically repairable at DSU and GSU activities and which normally are furnished by supply on an exchange basis. When items are determined by a GSU to be uneconomically repairable, they will be evacuated to a depot for evaluation and analysis before final disposition. |
| T | -High-dollar value recoverable repair parts which are subject to special handling and are issued on an exchange basis. Such repair parts normally are repaired or overhauled at depot maintenance activities. |
| U | -Repair parts specifically selected for salvage by reclamation units because of precious metal content, critical materials, or high-dollar value reusable casings or castings. |

b. Federal Stock Number, Column 2. This column indicates the Federal stock number assigned to the, item and will be used for requisitioning purposes.

c. Description, Column 3. This column indicates the Federal item name and any additional description of the item required. The index number has been included as part of the description to aid in the location of "same as" items. A part number of other reference number is followed by the applicable five-digit Federal supply code for manufacturers in parentheses.

d. Unit of Measure, Column 4. A 2-character alphabetic abbreviation indicating the amount or quantity of the item upon which the allowances are based, e.g., ft, ea, pr, etc.

e. Quantity Incorporated in Unit, Column 5. This column indicates the quantity of the item used in the AN/VSS-3. A "V" appearing in this column in lieu of a quantity indicates that a definite quantity cannot be indicated (e.g., shims, spacers, etc.).

f. 15-Day Organizational Maintenance Allowances, Column 3 of Section II and Column 6 of Section III.

(1) The allowance columns are divided into four subcolumns. Indicated in each subcolumn opposite the first appearance of each item is the total quantity of items authorized for the number of equipments supported. Subsequent appearances of the same item will have the letters "REF" in the allowance columns. Items authorized for use as required but not for initial stockage are identified with an asterisk in the allowance column.

(2) The quantitative allowances for organizational level of maintenance represents one initial prescribed load for a 15-day period for the number of equipments supported. Units and organizations authorized additional prescribed loads will multiply the number of prescribed loads authorized by the quantity of repair parts reflected in the density column applicable to the number of items supported to obtain the total quantity of repair parts authorized.

(3) Organizational units providing maintenance for more than 100 of these equipments shall determine the total quantity of parts required by converting the equipment quantity to a decimal factor by placing a decimal point before the next to last digit of the number to indicate hundredths, and multiplying the decimal factor, by the parts quantity authorized in the 51-100 allowance col-

umn. *Example*, authorized allowance for 51-100 equipments is 40; for 150 equipments multiply 40 by 1.50 or 60 parts required.

(4) Subsequent changes to allowances will be limited as follows: No change in the range of items is authorized. If additional items are considered necessary, recommendation should be forwarded to Commanding General, U.S. Army Electronics Command, ATTN: AMSEL-ME-NMP-EM, Fort Monmouth, N.J. 07703, for exception or revision to the allowance list. Revisions to the range of items authorized will be made by the USA ECOM National Maintenance Point based upon engineering experience, demand data, or TAERS information.

g. Illustration, Column 7. This column is divided as follows:

(1) *Figure number, column 7a.* Indicates the figure number of the illustration in which the item is shown.

(2) *Item number, column 7b.* Indicates the callout number used to reference the item in the illustration.

D-4. Special Information

Repair parts mortality is computed from failure rates derived from experience factors with the individual parts in a variety of equipments. Variations in the specific application and periods of use of electronics equipment, the fragility of electronic piece parts, plus intangible material and quality factors intrinsic to the manufacture of electronic parts, do not permit mortality to be based on hours of end item use. However, long periods of continuous use under adverse conditions are likely to increase repair parts mortality.

D-5. Location of Repair Parts

a. This appendix contains two cross-reference indexes (secs. V and VI) to be used to locate a repair part when either the Federal stock number, reference number (manufacturer's part number), or reference designation is known. The first column in each index is prepared in alphabetical sequence. The reference numbers (manufacturer's part numbers) are listed immediately following the last listed Federal stock number in the index of Federal stock numbers.

b. When the Federal stock number is known, follow the procedures given in (1), (2) and (3) below.

(1) Refer to the index of Federal stock numbers (sec. V) and locate the Federal stock number. The FSN is cross-referenced to the applicable figure and item or reference designation.

(2) Refer to the RPSTL (sec. III) and locate the figure number (col. 7a), and item or reference number (col. 7b), as noted in the FSN index.

(3) If the FSN or manufacturer's part number is not listed in the index, refer to columns 2 and 3 of the RPSTL (sec. III) and locate the Federal stock number or part number by scrutiny of the numbers listed in columns 2 and 3.

c. When the reference designation is determined, refer to the reference designation index (sec. VI). The reference designations are listed in alphanumeric order and are cross-referenced to the page number on which they appear in the repair parts list (sec. III). Refer to the page number noted in the index and locate the reference designation (col. 7b). If the word "REF" appears in the allowance column for the repair part, note the Federal stock number (col. 2) or manufacturer's part number (col. 3). Refer to the FSN index and note the reference designation for that FSN or part number. Refer to the reference designation index and note the page number given for the reference designation. Refer to the page noted in the RPSTL (sec. III) and locate the reference designation in column 7b of the repair parts list.

D-6. Federal Supply Code for Manufacturers

<i>Code</i>	<i>Manufacturer's name</i>
05301 -----	Engelhard Industries, Inc.
08806 -----	General Electric Co., Miniature Lamp Dept.
12143 -----	Bendix Corp, Electrical Components Division
12705 -----	Electro-Optical Systems, Inc.
15291 -----	Adjustable Bushing Corp.
25072 -----	Western Airmotive, Inc.
75915 -----	Littlefuse, Inc.
80058 -----	Joint Electronic Type Designation System
88044-----	Aeronautical Standards Group Dept of Navy and Air Force
96906-----	Military Standards

SECTION II. PRESCRIBED LOAD ALLOWANCE

(1) FEDERAL STOCK NUMBER	(2) DESCRIPTION USABLE ON CODE	(3) 15 DAY ORG. MAINT. ALLOWANCE			
		(a) 1-5	(b) 6-20	(c) 21-50	(d) 51-100
5305 -054 -5647	SCREW, MACHINE: MS51957-13; (96906)	2	2	2	2
5305-269-2803	SCREW, CAP, HEXAGONAL HEAD: MS90726-60; (96906)				2
5305-716-8186	SCREW, CAP, HEXAGONAL HEAD: MS90726-110; (96906)	2	2	2	2
5305-983-6651	SCREW, CAP, SOCKET HEAD: MS16998-27; (96906)				2
5310-061-1258	WASHER, LOCK: MS45904-76; (96906)				3
5310-632-6721	WASHER, FLAT: AN96004; (88044)	2	2	2	2
5310-721-7809	WASHER, LOCK: MS35340-43; (96906)				2
5310-767-9425	WASHER, FLAT: MS15795-818; (96906)	2	2	2	2
5310-933-8118	WASHER, LOCK: MS35338-135; (96906)	2	2	2	2
5340-134-3339	COUPLING, CLAMP, GROOVED: 1127019-1; (12705)	2	2	2	2
5340-143-0356	PIN, QUICK RELEASE: EGP8E24L8; (15291)	2	2	2	2
5855-135-0154	CONTROL, SEARCHLIGHT SET C-7906/VSS-3: (80058)	2	2	2	2
5855-135-0155	CONTROL, SEARCHLIGHT SET C-7905/VSS-3: (80058)	2	2	2	3
5855-135-0162	MOUNT, SEARCHLIGHT: 1122311-1; (12705)	2	2	2	2
5855-245-8452	HOLDER ASSEMBLY, LAMP SUPPORT: 1128310-1; (12705)	2	2	2	2
5920-295-9602	FUSE, CARTRIDGE: 313001; (75915)	2	2	2	2
5975-123-1527	COVER, SEARCHLIGHT: 1127001-1; (12705)	2	2	2	2
5995-135-0081	CABLE ASSEMBLY, POWER, ELECTRICAL CX-11893/VSS-3: (80058)	2	2	2	2
6230-168-0153	LAMP AND HOLDER ASSEMBLY: 1122328-1; (12705)	3	10	25	47
6240-155-7836	LAMP, INCANDESCENT: MS25237-327; (96906)		2	2	3
6240-851-4352	LAMP, INCANDESCENT: 330; (08806)			2	2

SECTION III. REPAIR PARTS FOR ORGANIZATIONAL MAINTENANCE

(1) SMR CODE	(2) FEDERAL STOCK NUMBER	(3) DESCRIPTION Reference Number & Mfr Code	(4) UNIT OF MEAS	(5) QTY INC IN UNIT	(6) 15-DAY ORGANIZATIONAL MAINTENANCE ALW				(7) ILLUSTRATIONS	
					(a) 1-5	(b) 6-20	(c) 21-50	(d) 51-100	(a) FIG NO.	(b) ITEM NO. OR REFERENCE DESIGNATION
1-0-S	5855-058-1293	A001 SEARCHLIGHT SET, INFRARED AN/VSS-3: (80058) (This item is non expendable)							1-1	
P-0	5995-135-0081	A002 CABLE ASSEMBLY, POWER, ELECTRICAL CX-11893/VSS-3 : (80058)	EA	1	2	2	2	2	1-1	4W
K1-0		A003 ADAPTER, POTTING : 10-242067-285 ; (12143)	EA	1						4WMP2
K1-0		A004 ADAPTER, POTTING: SAME AS A003	EA	1						4WMP1
P-0-S	5855-135-0155	A013 CONTROL, SEARCHLIGHT SET C-7905/VSS-3 : (80058)	EA	1	2	2	2	3	1-1	2
P-0	5305-269-2803	A014 SCREW, CAP, HEXAGONAL HEAD: MS90726-60 ; (96906)	EA	4	*	*	*	2	1-1	H4-4
P-0	5310-061-1258	A015 WASHER, LOCK: MS45904-76; (96906)	EA	4	*	*	*	3	1-1	H5-4
K1-0-S		A016 CONTROL, SUBASSEMBLY: 1126557-1; (12705)	EA	1						2A1
Q2-0	5935 -115-2305	A137 COVER, ELECTRICAL CONNECTOR: MS1734928B ; (96906)	EA	1					5-3	2A1MP9
Q2-0	5305-054-6652	A138 SCREW, MACHINE : MS51957-28; (96906)	EA	4					5-3	2A1H4-2
Q2-0	5310-722-5998	A139 WASHER, FLAT: MS15795-805; (96906)	EA	4					5-3	2A1H4-2
Q2-0	5310-929-6395	A140 WASHER, LOCK: MS35338-136; (96906)	EA	4					5-3	2A1H20-2
Q2-0	5935-581-2889	A141 COVER, ELECTRICAL CONNECTOR : MS25043-32C ; (96906)	EA	1					5-3	2A1MP11
Q2-0	5935 -500-5008	A142 COVER, ELECTRICAL CONNECTOR: MS25043-18C; (96906)	EA	1					5-3	2A1MP10
Q2-0	5305-054-6652	A143 SCREW, MACHINE: SAME AS A138	EA	1					5-3	2A1H4-2
Q2-0	5310-722-5998	A144 WASHER, FLAT: SAME AS A139	EA	1					5-3	2A1H4-2
Q2-0	5310-929-6395	A145 WASHER, LOCK: SAME AS A140	EA	1					5-3	2A1H20-2
P-0	5355-931-5383	A161 KNOB: MS91528-1E4B; (96906)	EA	1	*	*	*	*	5-3	2A1MP15
P-0	5355-881-0722	A162 KNOB: MS91528-1K4B ; (96906)	EA	1	*	*	*	*	5-3	2A1MP14
P-0	6240-851-4352	A163 LAMP, INCANDESCENT: 330; (08806)	EA	1	*	*	2	2	5-3	2A1DS3
P-0	6240-155-7836	A164 LAMP, INCANDESCENT: MS25237-327; (96906)	EA	1	*	2	2	3	5-3	2A1DS1
P-0	6240-155-7836	A165 LAMP, INCANDESCENT: SAME AS A164	EA	1	REF	REF	REF	REF	5-3	2A1DS2
P-0	6210-176-4955	A166 LENS, INDICATOR LIGHT (GREEN): LC35RT2 ; (25072)	EA	1	*	*	*	*	5-3	2A1MP16
P-0	6210-176-4954	A167 LENS, INDICATOR LIGHT (RED) : LC35RT2 ; (25072)	EA	1	*	*	*	*	5-3	2A1MP17
P-0	6210-176-4956	A168 LENS, INDICATOR LIGHT (WHITE) : LC35WT2 ; (25072)	EA	1	*	*	*	*	5-3	2A1MP18
P-0-S	5855-135-0154	A236 CONTROL, SEARCHLIGHT SET C-7906/VSS-3: (80058)	EA	1	2	2	2	2	1-1	3
P-0	5305-983-6651	A237 SCREW, CAP, SOCKET HEAD : MS16998-27 ; (96906)	EA	4	*	*	*	2	1-1	H2-4
P-0	5310-721-7809	A238 WASHER, LOCK: MS35340-43; (96906)	EA	4	*	*	*	2	1-1	H3-4
P-0	6240-155-7836	A249 LAMP, INCANDESCENT: SAME AS A164	EA	1	REF	REF	REF	REF	5-3	3DS1
P-0	6240-155-7836	A250 LAMP, INCANDESCENT: SAME AS A164	EA	1	REF	REF	REF	REF	5-3	3DS2
P-0	6210-176-4955	A251 LENS, INDICATOR LIGHT (GREEN) : SAME AS A166	EA	1	REF	REF	REF	REF	5-3	3MP8
P-0	6210-176-4954	A252 LENS, INDICATOR LIGHT (RED): SAME AS A167	EA	1	REF	REF	REF	REF	5-3	3MP7
P-0	5975-123-1527	A264 COVER, SEARCHLIGHT : 1127001-1 ; (12705)	EA	1	2	2	2	2	1-1	MP1
P-0	6250-134-1757	A265 HOLDER, LAMP: 1126904-1; (12705)	EA	1	*	*	*	*	1-1	MP2
P-0-U	6230-168-0153	A266 LAMP AND HOLDER ASSEMBLY: 1122328-1 ; (12705)	EA	1	3	10	25	47	1-1	A1

SECTION III. REPAIR PARTS FOR ORGANIZATIONAL MAINTENANCE (CONTINUED)

(1) SMR CODE	(2) FEDERAL STOCK NUMBER	(3) DESCRIPTION Reference Number & Mfr Code	(4) UNIT OF MEAS	(5) QTY INC IN UNIT	(6) 15-DAY ORGANIZATIONAL MAINTENANCE ALW				(7) ILLUSTRATIONS	
					(a) 1-5	(b) 6-20	(c) 21-50	(d) 51-1	(a) FIG NO.	(b) ITEM NO. OR REFERENCE DESIGNATION
P-0	6250-134-1757	A267 HOLDER, LAMP: SAME AS A265	EA	1	REF	REF	REF	REF	5-2	A1MP1
KL-0		A268 LAMP, XENON: 936271; (05301)	EA	1					5-2	A1DS1
P-0	5855-135-0162	A269 MOUNT, SEARCHLIGHT: 1122311-1; (12705)	EA	1	2	2	2	2	1-1	MP2
P-0	5305-716-8186	A270 SCREW, CAP, HEXAGONAL HEAD: MS90726-110; (96906)	EA	4	2	2	2	2	1-1	H7-4
P-0	5310-767-9425	A271 WASHER, FLAT: MS15795-818; (96906)	EA	4	2	2	2	2	1-1	H6-4
P-0	5340-143-0356	A272 PIN, QUICK RELEASE: BOP6E24I8; (15291)	EA	3	2	2	2	2	1-1	H1-3
J-0-S	5855-135-0156	A273 SEARCHLIGHT, INFRARED MX-8272/VSS-3: (80058) (This item is nonexpendable)	EA	1					1-1	1
P-0	5340-134-3339	A274 COUPLING, CLAMP, GROOVED: 1127019-1; (12705)	EA	1	2	2	2	2	5-1	1MP6
P-0	5920-295- 9602	A532 FUSE, CARTRIDGE: 313001; (75915)	EA	1	2	2	2	2	1-4	1A2F1
P-0	5920-295-9602	A533 FUSE, CARTRIDGE : SAME AS A532	EA	1	REF	REF	REF	REF	1-4	1A2F2
P-0	5855-245-8452	A560 HOLDER ASSEMBLY, LAMP SUPPORT : 1128310-1 ; (12705)	EA	1	2	2	2	2	5-2	1A2A12
P-0	5305-054-5647	A561 SCREW, MACHINE : MS51957-13 ; (96906)	EA	4	2	2	2	2	5-2	1A2H25-4
P-0	5310-632-6721	A562 WASHER, FLAT: AN96004 ; (88044)	EA	4	2	2	2	2	5-2	1A2H36-4
P-0	5310-933-8118	A563 WASHER, LOCK: MS35338-135 ; (96906)	EA	4	2	2	2	2	5-2	1A2H67-4
KL-0		A564 CLIP, LAMP SUPPORT: 1122322-1 ; (12705)	EA	1						1A2A12MP1
KL-0		A565 RING, LAMP SUPPORT: 1128308-1 ; (12705)	EA	1						1A2A12MP2
KL-0		A566 RIVET, SOLID: MS20470B2-2 ; (96906)	EA	4						1A2A12H1
P-0-U	6230-168-0153	A581 LAMP AND HOLDER ASSEMBLY : SAME AS A266	EA	1	REF	REF	REF	REF	5-2	A1
P-0	6250-134-1757	A582 HOLDER, LAMP: SAME AS A265	EA	1	REF	REF	REF	REF	1-1	MP2
KL-0		A583 LAMP, XENON: SAME AS A268	EA	1					1-5	1A2DS1

SECTION V. INDEX-FEDERAL STOCK NUMBER CROSS REFERENCE
 TO FIGURE AND ITEM NUMBER OR REFERENCE DESIGNATION

FEDERAL STOCK NUMBER	FIGURE NUMBER	ITEM NUMBER OR REF. DESIGNATION	FEDERAL STOCK NUMBER	FIGURE NUMBER	ITEM NUMBER OR REF. DESIGNATION
5305-054-5647	5-2		6210-176-4956	5-3	2A1MP18
5305-054-6652	5-3	2A1H44-2	6230-168-0153	1-1	A1
5305-054-6652	5-3	2A1H44-2	6230-168-0153	5-2	A1
5305-269-2803	1-2	H4-4	6240-155-7836	5-3	2A1DS1
5305-716-8186	1-1	H7-4	6240-155-7836	5-3	2A1DS2
5305-983-6651	1-1	H2-4	6240-155-7836	5-3	3DS1
5310-061-1258	1-1	H5-4	6240-155-7836	5-3	3DS2
5310-632-6721	5-2	1A2H36-4	6240-851-4352	5-3	2A1DS3
5310-721-7809	1-1	H3-4	6250-134-1757	1-1	MP2
5310-722-5998	5-3	2A1H4-2	6250-134-1757	1-1	MP2
5310-722-5998	5-3	2A1H4-2	6250-134-1757	5-2	A1MP1
5310-767-9425	1-1	H6-4	<u>REF. NO.</u>	<u>MFG CODE</u>	<u>FIG NO.</u>
5310-929-6395	5-3	2A1H20-2	MS20470B2-2	96906	1A2A12H1
5310-929-6395	5-3	2A1H20-2	10-242067-285	12143	4WMP1
5310-933-8118	5-2	1A2H67-4	10-242067-285	12143	4WMP2
5340-134-3339	5-1	LMP6	1122322-1	12705	1A2A12MP1
5340-143-0356	1-1	H1-3	1126557-1	12705	2A1
5355-881-0722	5-3	2A1MP14	1128308-1	12705	1A2A12MP2
5355-931-5383	5-3	2A1MP15	936271	05301	1-5
5855-135-0154	1-1	3	936271	05301	5-2
5855-135-0155	1-1	2			1A2DS1
5855-135-0156	1-1	1			A1DS1
5855-135-0162	1-1	MP2			
5855-245-8452	5-2	1A2A12			
5920-295-9602	1-4	1A2F1			
5920-295-9602	1-4	1A2F2			
5935-115-2305	5-3	2A1MP9			
5935-500-5008	5-3	2A1MP10			
5935-581-2889	5-3	2A1MP11			
5975-123-1527	1-1	MP1			
5995-135-0081	1-1	4W			
6210-176-4954	5-3	2A1MP17			
6210-176-4954	5-3	3MP7			
6210-176-4955	5-3	2A1MP16			
6210-176-4955	5-3	3MP8			

SECTION VI. INDEX- DESIGNATION
CROSS REFERENCE TO PAGE NUMBER

REFERENCE DESIGNATION	PAGE NUMBER	REFERENCE DESIGNATION	PAGE NUMBER	REFERENCE DESIGNATION	PAGE NUMBER
A1	D-5	2A1H20-2	D-5		
A1	D-5	2A1H20-2	D-5		
A1DS1	D-6	2A1H44-2	D-5		
A1MP1	D-6	2A1H44-2	D-5		
H1-3	D-6	2A1MP9	D-5		
H2-4	D-5	2A1MP10	D-5		
H3-4	D-5	2A1MP11	D-5		
H4-4	D-5	2A1MP14	D-5		
H5-4	D-5	2A1MP15	D-5		
H6-4	D-6	2A1MP16	D-5		
H7-4	D-6	2A1MP17	D-5		
MP1	D-5	2A1MP18	D-5		
MP2	D-5	3	D-5		
MP2	D-5	3DS1	D-5		
1	D-6	3DS2	D-5		
1A2A12	D-6	3MP7	D-5		
1A2A12H1	D-6	3MP8	D-5		
1A2A12MP1	D-6	4W	D-5		
1A2A12MP2	D-6	3WMP1	D-5		
1A2DS1	D-6	4WMP2	D-5		
1A2F1	D-6				
1A2F2	D-6				
1A2H25-4	D-6				
1A2H36-4	D-6				
1A2H67-4	D-6				
1MP6	D-6				
2	D-5				
2A1	D-5				
2A1DS1	D-5				
2A1DS2	D-5				
2A1DS3	D-5				
2A1H4-2	D-5				
2A1H4-2	D-5				

INDEX

	Paragraph	Page
Additional equipment required	1-10	1-8
Adjustments, beam width	3-6	3-2
Arctic climates, operation	3-11	3-4
Authority for demolition	6-3	6-1
Beam width adjustments	3-6	3-2
Characteristics, technical	1-5	1-3
Chart:		
Operator's weekly preventive maintenance checks and services	4-5	4-1
Organizational monthly preventive maintenance checks and services	5-5	5-1
Checking unpacked equipment	2-3	2-1
Checks and services required	4-4	4-1
Cleaning procedures:		
Operator's	4-6	4-2
Organizational	5-7	5-2
Common names	1-7	1-3
Components, table	1-6	1-3
Control box, replacement	5-15	5-7
Control settings, preliminary	3-4	3-2
Controls, searchlight	3-1	3-1
Demolition, authority	6-3	6-1
Description:		
Equipment (figs. 1-1 through 1-9)	1-8	1-4
Minor components	1-9	1-8
Desert climates, operation	3-13	3-4
Destruction:		
Methods	6-5	6-1
Plan	6-4	6-1
Disassembly	6-1	6-1
Disposal, methods	6-6	6-2
Equipment:		
Description	1-8	1-4
Function (fig. 1-10)	1-12	1-11
Required, additional	1-10	1-8
Emergency stopping procedure	3-9	3-3
Exchanger, heat	3-3	3-2
F o r d i n g	3-10	3-3
Forms and records	1-3	1-1
Function, equipment	1-12	1-11
Fuses, replacement	5-10	5-4
General:		
Basic principles	1-11	1-10
Installation procedures	2-4	2-4
Organizational troubleshooting and repairs	5-8	5-2
Service upon receipt of AN/VSS-3	2-1	2-1
Heat exchanger	3-3	3-2
Indexes of publications	1-2	1-1
Indicator lamps, replacement	5-18	5-9
Indicators, searchlight	3-2	3-1
Limited storage shipment	6-2	6-1
Lubrication	4-8	4-3

	Paragraph	Page
Materials required for operator maintenance -----	4-2	4-1
Methods:		
Destruction -----	6-5	6-1
Disposal -----	6-6	6-2
Minor components, description -----	1-9	1-8
Modes of operation -----	3-7	3-3
Monthly maintenance, organizational -----	5-4	5-1
Names, common -----	1-7	1-3
Normal stopping procedure -----	3-8	3-3
Operation:		
Arctic climates -----	3-11	3-4
Desert climates -----	3-13	3-4
Modes -----	3-7	3-3
Tropical climates -----	3-12	3-4
Under saltwater spray environments -----	3-14	3-4
Operator maintenance:		
Cleaning procedures -----	4-6	4-2
Materials required -----	4-2	4-1
Preventive maintenance -----	4-3	4-1
Scope -----	4-1	4-1
Troubleshooting chart -----	4-9	4-3
Troubleshooting procedures -----	4-8	4-3
Weekly preventive maintenance checks and services chart -----	4-5	4-1
Organizational maintenance:		
Cleaning procedures -----	5-7	5-2
Monthly maintenance -----	5-4	5-1
Monthly preventive maintenance checks and services -----	5-5	5-1
Preventive maintenance -----	5-3	5-1
Scope -----	5-1	5-1
Tools and materials required -----	5-2	5-1
Troubleshooting chart -----	5-9	5-3
Painting and refinishing procedure -----	5-6	5-2
Plan, destruction -----	6-4	6-1
Power cable, replacement -----	5-16	5-7
Preliminary control settings -----	3-4	3-2
Preventive maintenance:		
Operator's -----	4-3	4-1
Organizational -----	5-3	5-1
Procedure:		
Emergency stopping -----	3-9	3-3
Normal stopping -----	3-8	3-3
Painting and refinishing -----	5-6	5-2
Starting -----	3-5	3-2
Publications, indexes -----	1-2	1-1
Purpose and use (fig. 1-1) -----	1-4	1-1
Records, forms -----	1-3	1-1
Remote control box, replacement -----	5-17	5-8
Replacement:		
Control box -----	5-15	5-7
Fuses -----	5-10	5-4
Indicator lamps (fig. 5-3) -----	5-18	5-9
Power cable -----	5-16	5-7
Remote control box -----	5-17	5-8
Searchlight -----	5-13	5-7
Searchlight mount -----	5-14	5-7
Switch knobs -----	5-19	5-9
Window (fig. 5-1) -----	5-1	5-1
Xenon lamp (fig. 5-2) -----	5-12	5-5
Required checks and services -----	4-4	4-1
Salt water spray environments, operation under -----	3-14	3-4

	Paragraph	Page
Searchlight:		
Controls-----	3-1	3-1
Indicators-----	3-2	3-1
Mount, replacement -----	5-14	5-7
Replacement-----	5-13	5-7
Servicing-----	2-5	2-4
Shipment or limited storage-----	6-2	6-1
Starting procedure-----	3-5	3-2
Switch knobs, replacement -----	5-19	5-9
Table of components-----	1-6	1-3
Technical characteristics-----	1-5	1-3
Tools and materials required for organizational maintenance -----	5-2	5-1
Tropical climates, operation-----	3-12	3-4
Troubleshooting:		
Chart:		
Operator-----	4-9	4-3
Organizational-----	5-9	5-3
Procedures, operator-----	4-8	4-3
Unpacked equipment, checking-----	2-3	2-1
Unpacking (fig. 2-1)-----	2-2	2-1
Window, replacement-----	5-11	5-4
Xenon lamp replacement-----	5-12	5-5

By Order of the Secretary of the Army:

W. C. WESTMORELAND,
General, United States Army,
Chief of Staff.

Official:

KENNETH G. WICKHAM,
Major General, United States Army,
The Adjutant General.

Distribution:

Active Army:

USASA (2)	USACDCEC (10)
CNGB (1)	SigFLDMS (1)
USACDCCEA (1)	Depots (1) except
USACDCCEA	LEAD (3)
Ft Huachuca (1)	TOAD (5)
USAMB (10)	SAAD (5)
USAMC (1)	ATAD (5)
USCONARC (5)	GENDEPS (2)
OS MAJ COMD (5)	Sig Dep (3)
LOGCOMD (2) except	Sig Sec GENDEPS (3)
1st LOG COMD (10)	USMACV (50)
9th LOG COMD (10)	Units org under fol TOE :
Armies (5) except	(2 cys ea unit)
8th US Army (15)	11-158
USARV (20)	17
USAARENBD (2)	17-15
USAECOM (10)	17-16
MAAG (2)	17-17
USARMIS (2)	17-37
USAARMS (30)	17-42
USAOC&S (5)	17-51
USAAMS (30)	37
USAIS (30)	37-100
USAES (5)	37-102
USATC Armor (5)	

NG: State AG (3).

USAR: None.

For explanation of abbreviations used, see AR 310-50.

RECOMMENDED CHANGES TO EQUIPMENT TECHNICAL PUBLICATIONS



THEN...JOT DOWN THE
DOPE ABOUT IT ON THIS FORM.
CAREFULLY TEAR IT OUT, FOLD IT
AND DROP IT IN THE MAIL.

SOMETHING WRONG WITH PUBLICATION

FROM: (PRINT YOUR UNIT'S COMPLETE ADDRESS)

DATE SENT

PUBLICATION NUMBER

PUBLICATION DATE

PUBLICATION TITLE

BE EXACT PIN-POINT WHERE IT IS

PAGE
NO.

PARA-
GRAPH

FIGURE
NO.

TABLE
NO.

IN THIS SPACE, TELL WHAT IS WRONG
AND WHAT SHOULD BE DONE ABOUT IT.

TEAR ALONG PERFORATED LINE

PRINTED NAME, GRADE OR TITLE AND TELEPHONE NUMBER

SIGN HERE

THE METRIC SYSTEM AND EQUIVALENTS

WEIGHT MEASURE

1 Centimeter = 10 Millimeters = 0.01 Meters = 0.3937 Inches
 1 Meter = 100 Centimeters = 1000 Millimeters = 39.37 Inches
 1 Kilometer = 1000 Meters = 0.621 Miles

WEIGHTS

1 Gram = 0.001 Kilograms = 1000 Milligrams = 0.035 Ounces
 1 Kilogram = 1000 Grams = 2.2 lb.
 1 Metric Ton = 1000 Kilograms = 1 Megagram = 1.1 Short Tons

LIQUID MEASURE

1 Milliliter = 0.001 Liters = 0.0338 Fluid Ounces
 1 Liter = 1000 Milliliters = 33.82 Fluid Ounces

SQUARE MEASURE

1 Sq. Centimeter = 100 Sq. Millimeters = 0.155 Sq. Inches
 1 Sq. Meter = 10,000 Sq. Centimeters = 10.76 Sq. Feet
 1 Sq. Kilometer = 1,000,000 Sq. Meters = 0.386 Sq. Miles

CUBIC MEASURE

1 Cu. Centimeter = 1000 Cu. Millimeters = 0.06 Cu. Inches
 1 Cu. Meter = 1,000,000 Cu. Centimeters = 35.31 Cu. Feet

TEMPERATURE

$5/9(^{\circ}\text{F} - 32) = ^{\circ}\text{C}$
 212° Fahrenheit is equivalent to 100° Celsius
 90° Fahrenheit is equivalent to 32.2° Celsius
 32° Fahrenheit is equivalent to 0° Celsius
 $9/5^{\circ}\text{C} + 32 = ^{\circ}\text{F}$

APPROXIMATE CONVERSION FACTORS

TO CHANGE	TO	MULTIPLY BY
Inches	Centimeters	2.540
Feet	Meters	0.305
Yards	Meters	0.914
Miles	Kilometers	1.609
Square Inches	Square Centimeters	6.451
Square Feet	Square Meters	0.093
Square Yards	Square Meters	0.836
Square Miles	Square Kilometers	2.590
Acres	Square Hectometers	0.405
Cubic Feet	Cubic Meters	0.028
Cubic Yards	Cubic Meters	0.765
Fluid Ounces	Milliliters	29.573
its	Liters	0.473
arts	Liters	0.946
allons	Liters	3.785
Ounces	Grams	28.349
Pounds	Kilograms	0.454
Short Tons	Metric Tons	0.907
Pound-Feet	Newton-Meters	1.356
Pounds per Square Inch	Kilopascals	6.895
Miles per Gallon	Kilometers per Liter	0.425
Miles per Hour	Kilometers per Hour	1.609

TO CHANGE	TO	MULTIPLY BY
Centimeters	Inches	0.394
Meters	Feet	3.280
Meters	Yards	1.094
Kilometers	Miles	0.621
Square Centimeters	Square Inches	0.155
Square Meters	Square Feet	10.764
Square Meters	Square Yards	1.196
Square Kilometers	Square Miles	0.386
Square Hectometers	Acres	2.471
Cubic Meters	Cubic Feet	35.315
Cubic Meters	Cubic Yards	1.308
Milliliters	Fluid Ounces	0.034
Liters	Pints	2.113
Liters	Quarts	1.057
ers	Gallons	0.264
ms	Ounces	0.035
ograms	Pounds	2.205
Metric Tons	Short Tons	1.102
Newton-Meters	Pounds-Feet	0.738
Kilopascals	Pounds per Square Inch	0.145
ometers per Liter	Miles per Gallon	2.354
ometers per Hour	Miles per Hour	0.621

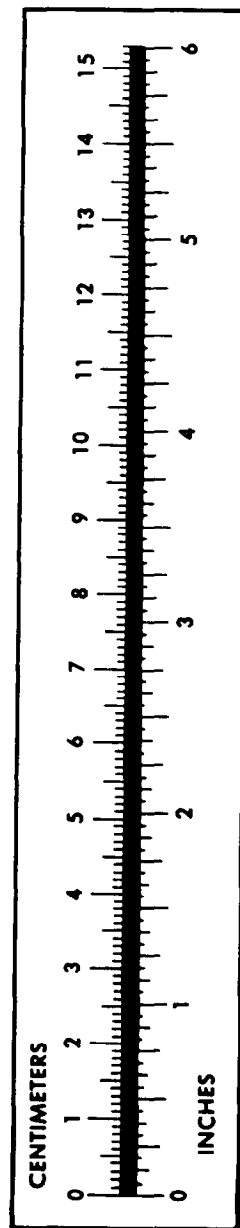

PIN: 018627-002

This fine document...

Was brought to you by me:



[Liberated Manuals -- free army and government manuals](#)

Why do I do it? I am tired of sleazy CD-ROM sellers, who take publicly available information, slap “watermarks” and other junk on it, and sell it. Those masters of search engine manipulation make sure that their sites that sell free information, come up first in search engines. They did not create it... They did not even scan it... Why should they get your money? Why are not letting you give those free manuals to your friends?

I am setting this document FREE. This document was made by the US Government and is NOT protected by Copyright. Feel free to share, republish, sell and so on.

I am not asking you for donations, fees or handouts. If you can, please provide a link to liberatedmanuals.com, so that free manuals come up first in search engines:

<A HREF=<http://www.liberatedmanuals.com/>>Free Military and Government Manuals

- Sincerely
Igor Chudov
<http://igor.chudov.com/>
- [Chicago Machinery Movers](#)